

# MATCHITECTURE

Gold Rush Train  
Train de la ruée vers l'or  
Tren de la fiebre del Oro  
Goldrausch-Eisenbahn  
Goudzoekerstrein  
Treno della febbre dell'oro



21"/54 cm

MICROBEAM cutter • Coupe-MICROMADRIER •  
CortaMICROVIGA • MIKROSTÄBE-Schneider •  
MICROBALK snijder •  
Tagliere per MICROTRAVE



### Gold Rush Train

It was in 1849 that the American Gold Rush began. During the next few years this movement resulted in the construction of the Central Pacific Railroad in 1861, the first Trans-American railroad. Hundreds of thousands of new immigrants arrived from California in a long and arduous journey by train across the desert and the Rocky Mountains.

### Tren de la ruée vers l'or

C'est en 1849 que la ruée vers l'or américaine a débuté. Durant les années suivantes, cette ruée a entraîné la construction du Central Pacific Railroad, la première voie ferrée trans-américaine. Des centaines de milliers de nouveaux immigrants arrivèrent en train par un long voyage à travers le désert et les montagnes Rocheuses.

### Tren de la fiebre del Oro

En 1849 comenzó la fiebre del oro americana. Durante las años siguientes este movimiento resultó en la construcción del Central Pacific Railroad, en 1861, el primer ferrocarril transamericano. Cientos de miles nuevos inmigrantes llegaron a California después de un viaje largo y agotador en tren a través del desierto y las Montañas Rocosas.

### Goldrausch-Eisenbahn

Im Jahr 1849 begann die amerikanische Goldrausch. Während der nächsten Jahre führte diese Auswanderung im Jahr 1861 zum Bau der Central Pacific Railroad, der ersten transamerikanischen Eisenbahn. Hunderte Tausende von neuen Immigranten zogen nach Kalifornien auf einer langen und beschwerelichen Reise mit der Eisenbahn quer durch die Wüste und die Rocky Mountains.

### Goldzoekerstein

De Amerikaanse goudkoorts begon in 1849. Daarna werd tijdens de meestejders jaren, vanaf 1861, de Central Pacific Railroad aangelegd die eerste trans-Amerikaanse spoorweg. Honderdduizenden emigranten trokken naar Californië tijdens een lange en harde reisreis doorheen de woestijn en de Rocky Mountains.

### Treno della febbre dell'oro

Nel 1849 iniziò la febbre dell'oro americana. Nel giro di pochi anni il movimento si allargò e culminò nel 1861 con la costruzione della Central Pacific Railroad, la prima ferrovia transamericana. Centinaia di migliaia di immigranti si stabilirono in California dopo aver fatto un lungo e faticoso viaggio in treno attraverso il deserto e le Montagne Roccose.

1849年、アメリカで金鉱熱が起りました。数年のうちに、この熱はますます大きくなり、1861年に中央太平洋鉄道が完成し、初めての大陸横断鉄道となりました。何百万人もの移民がカリフォルニアを目指して、長いとてつないだ旅を続けました。

# MATCHITECTURE

PLANS • PLANOS • PIANI • ZEICHNUNGEN • PLANNEN • 設計図

Wigan plans free in  
Plans du wagon gratuits en  
Los planes del vagón pueden obtenerse gratuitamente en  
Plans für Wagons kostenlos erhältlich bei  
Gratis wagonplannen op  
En schemi gratuiti dei vagoni si trovano sul sito  
[www.matchitecture.com](http://www.matchitecture.com)

WILSON JEFFERSON ARCHITECTS ASSOCIATES, SAN FRANCISCO, CA  
1 415 774 2400 ext. 101



### Conteúdo:

- 1 cavida d'asserraglio con foglio in acetato trasparente
- 4 clippe
- 1 tagliando per MICROBALL
- 1.000 MICROTRAM (53 mmx2 1/8") colla per legno (40 ml/1,35 oz)
- 1 pinzetta per MICROTRAM
- 1 piano (Laminazione schiuma) 10x20x2

### Inhalt:

- 1 nachgeplante mit durchsichtigen Acetablat
- 4 clippe
- 1 MIKROSTRASCHNITT
- 1000 MIKROSTRE (53 mmx2 1/8") Kleber für Holz (40 ml/1,35 oz)
- 1 Pinzette für die MIKROSTRABE
- 1 Zeichnung (für die Laminierung) verbleiben

### Inhoud:

- 1 nentegpland met transparant blad van acetate
- 4 klampen
- 1 snijder voor MICROBALL'S
- 1.000 MICROBALL'S (53 mmx2 1/8") lijm voor MICROBALL'S
- 1 pincet voor MICROBALL'S
- 1 plaat (Afschuim laminaat) gebuiscassaplaagje

### 内容:

- 1 透明シートと組み立てボード
- 4 クリップ
- 1 マイクロボールカッター
- 1000 マイクロボール (53 mmx2 1/8")
- 1 木工用糊 (40ml/1.35oz)
- 1 マイクロボールピンセット
- 1 設計図 (積層板のみ)
- 1 使用説明書

### Contenu:

- 1 placote d'asserrage avec feuille d'acétat transparente
- 4 clippe
- 1 coupe-MICROBALLIER
- 1.000 MICROBALLIERS (53 mmx2 1/8") colle à bois (40 ml/1,35 oz)
- 1 pince à MICROBALLIERS
- 1 plan (Lamination schuim) verbleiben

### Contenido:

- 1 tablero de ensamblaje con hoja de acetato transparente
- 4 pinzas
- 1 cortador MICROBOLA
- 1.000 MICROBOLAS (53 mmx2 1/8") pegamento de madera (40 ml/1,35 oz)
- 1 pinza para MICROBOLAS
- 1 plano (La laminação schuim) verbleiben

### Contents:

- 1 assembly board with clear acetate sheet
- 4 clips
- 1 MICROBLAM cutter
- 1.000 MICROBLAMS (2 1/8" x 7/8" mm)
- 1 wood glue (1.35 oz/40 ml)
- 1 MICROBLAM tweezers
- 1 plan (Laminatie-afschuim)
- 1 instructieboekje

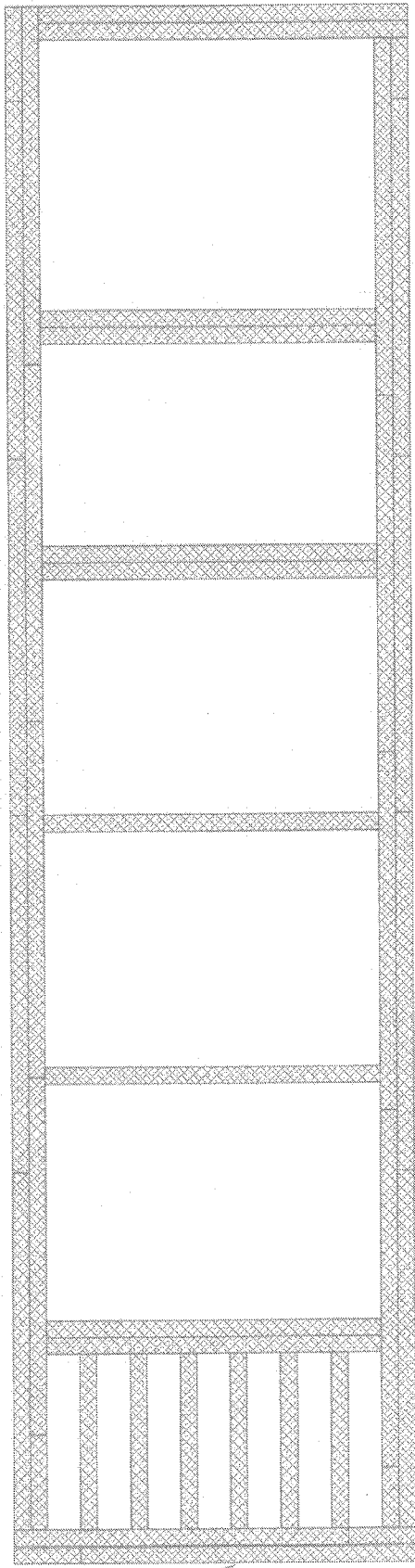

1

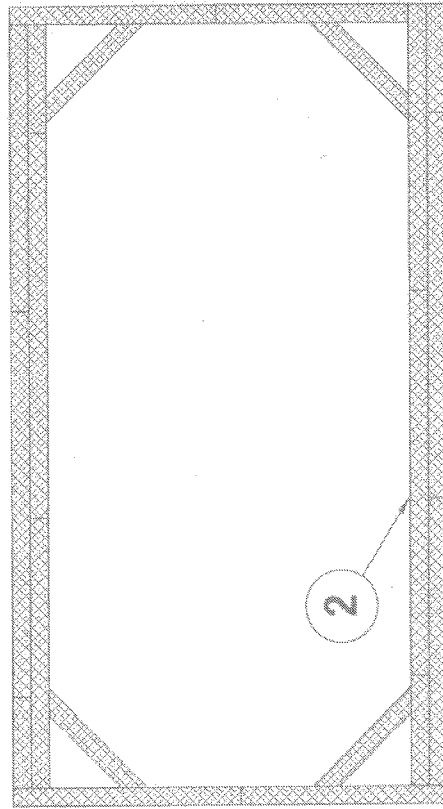

2

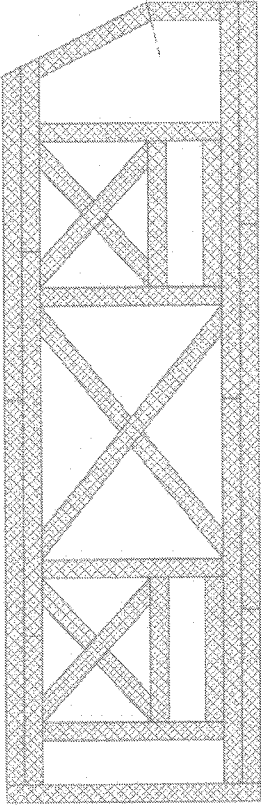

3

16x 4

2x 6

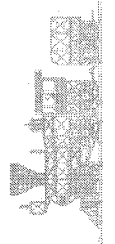
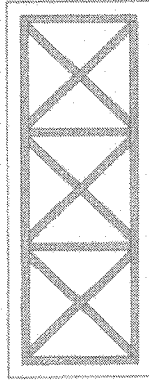
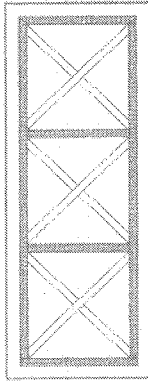
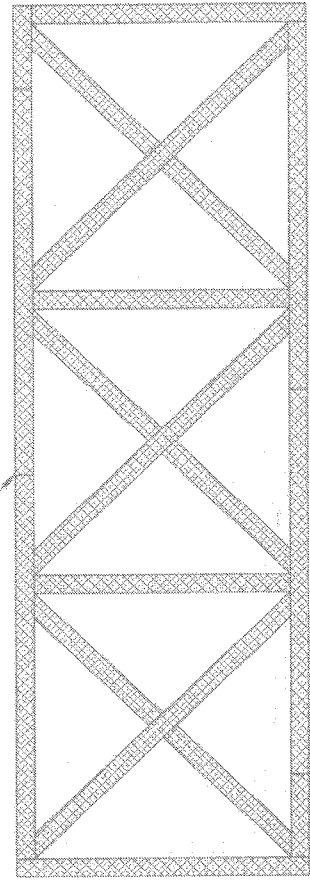

© 2004 Bojeux Inc.

www.matchitecture.com

MATCHITECTURE

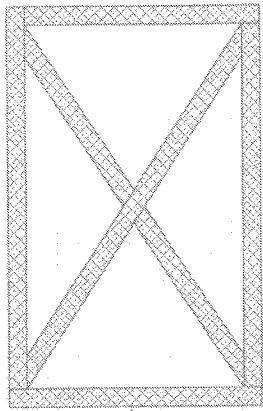

3x5

2x10

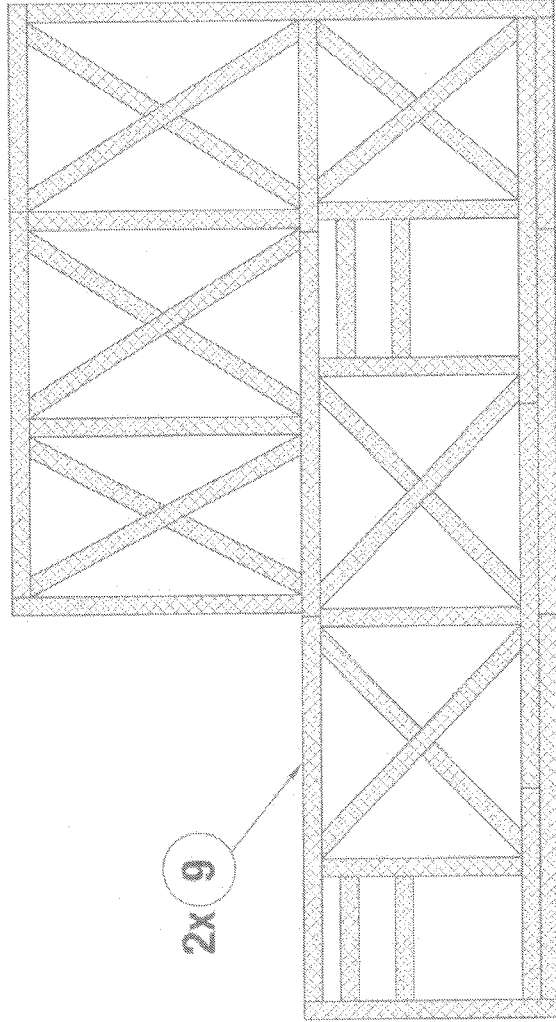
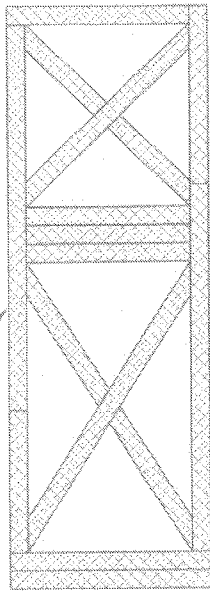

2x9

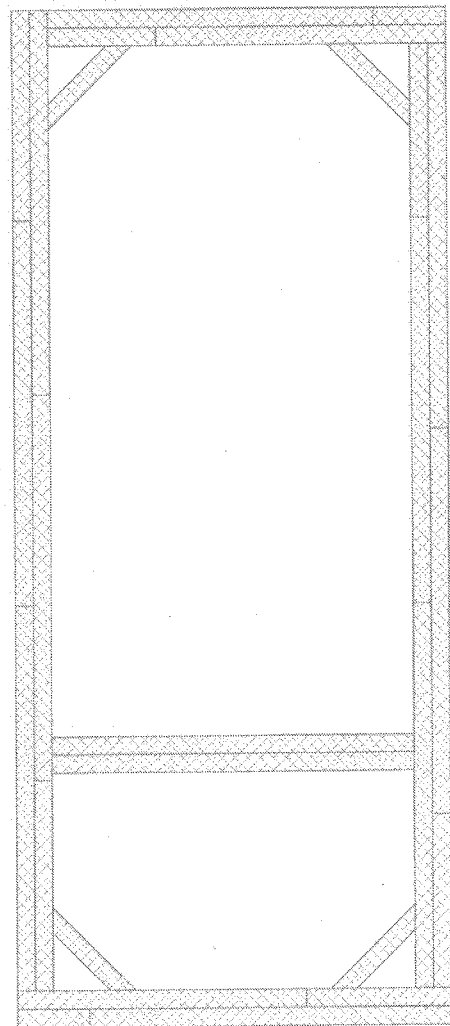

7

2x8

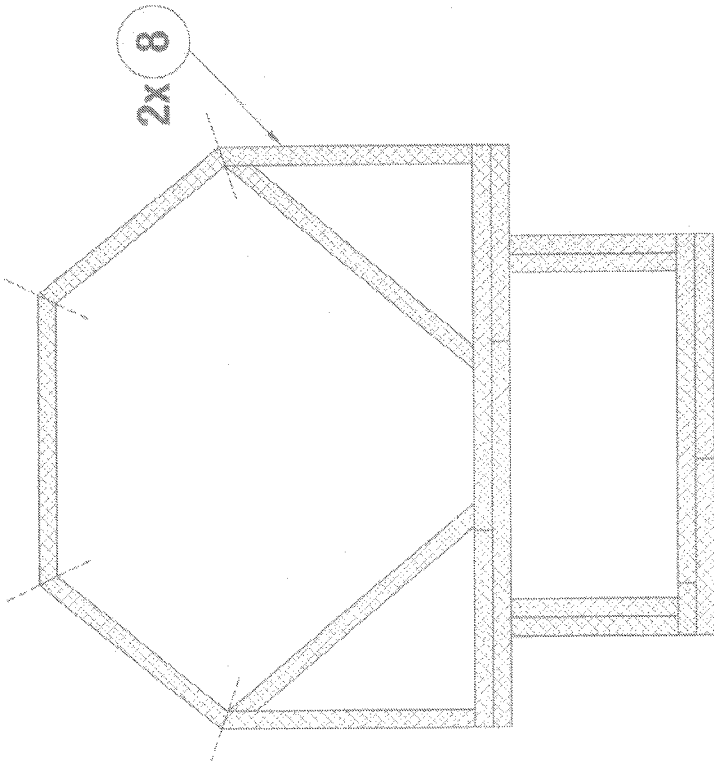

© 2003 Esjeux Inc.

www.matchitecture.com

MATCHITUDE

2/39

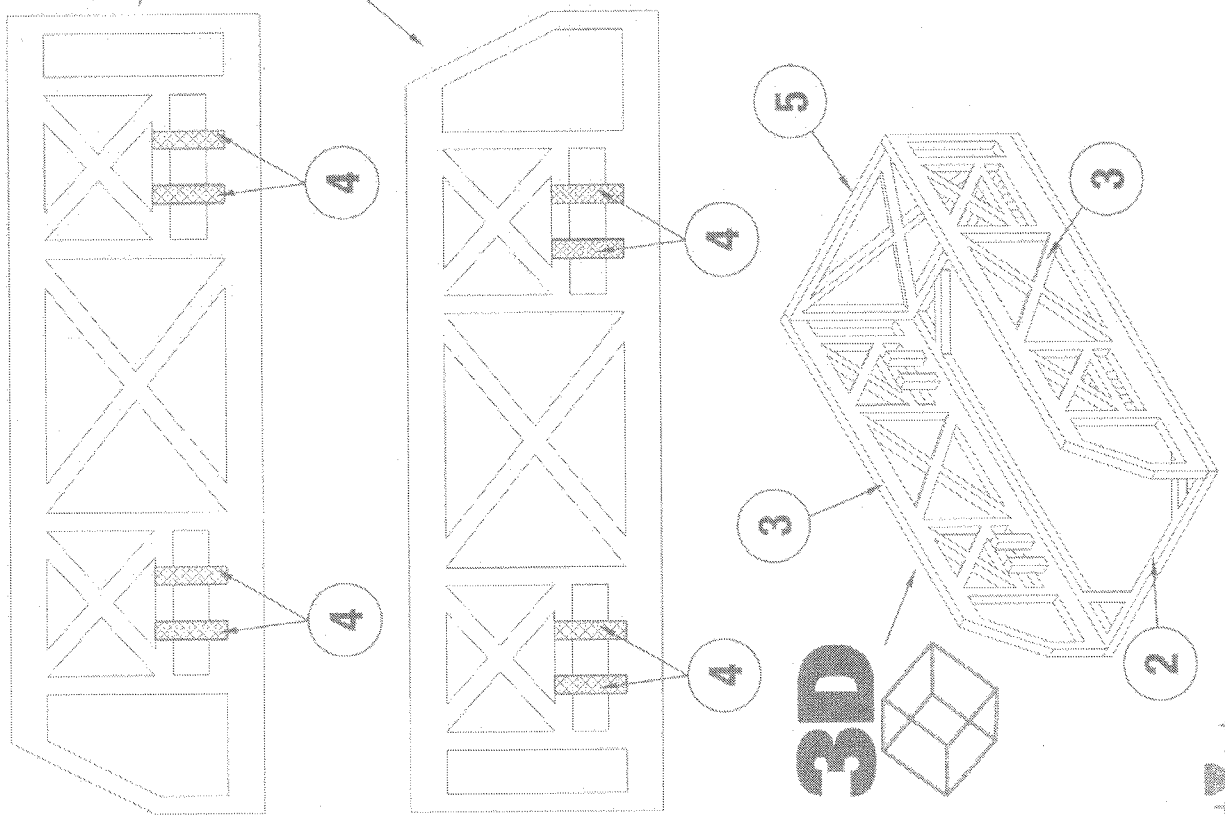
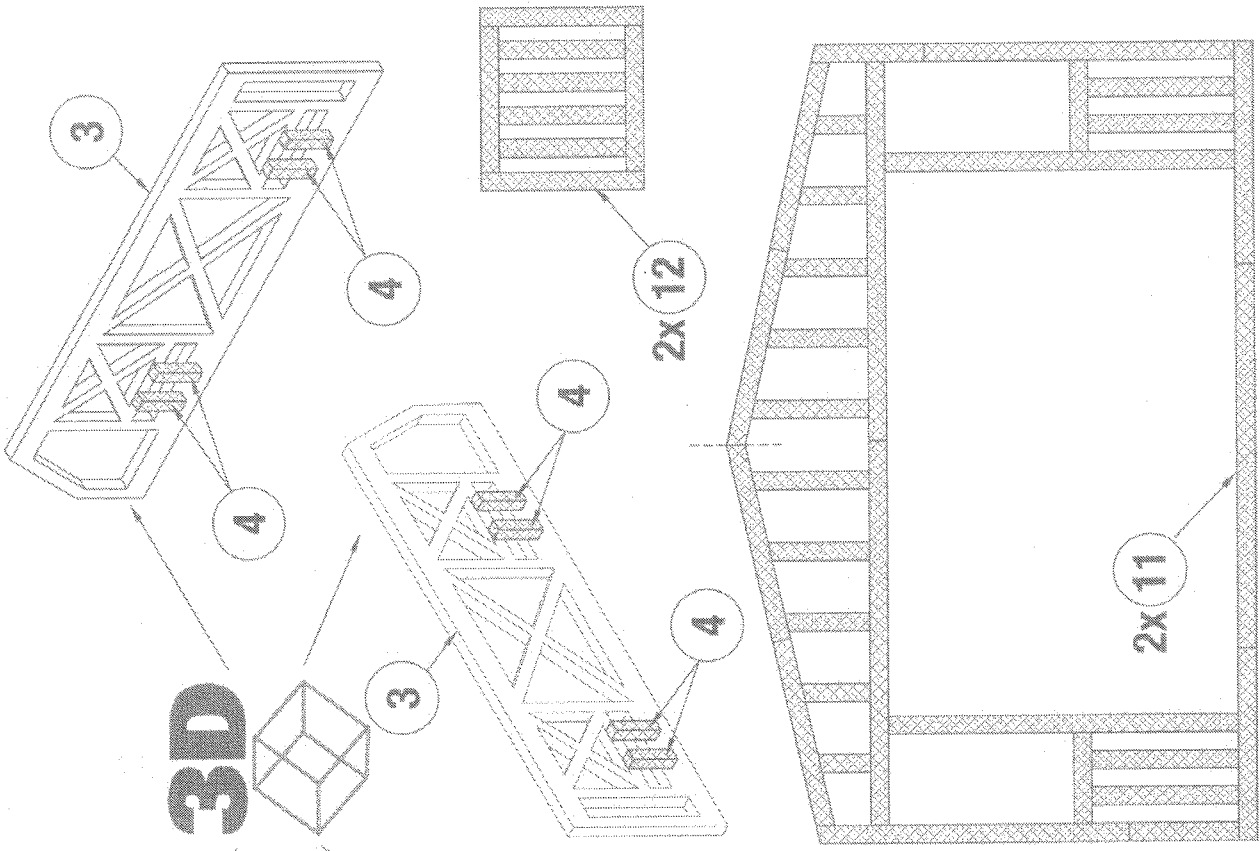

**3D**

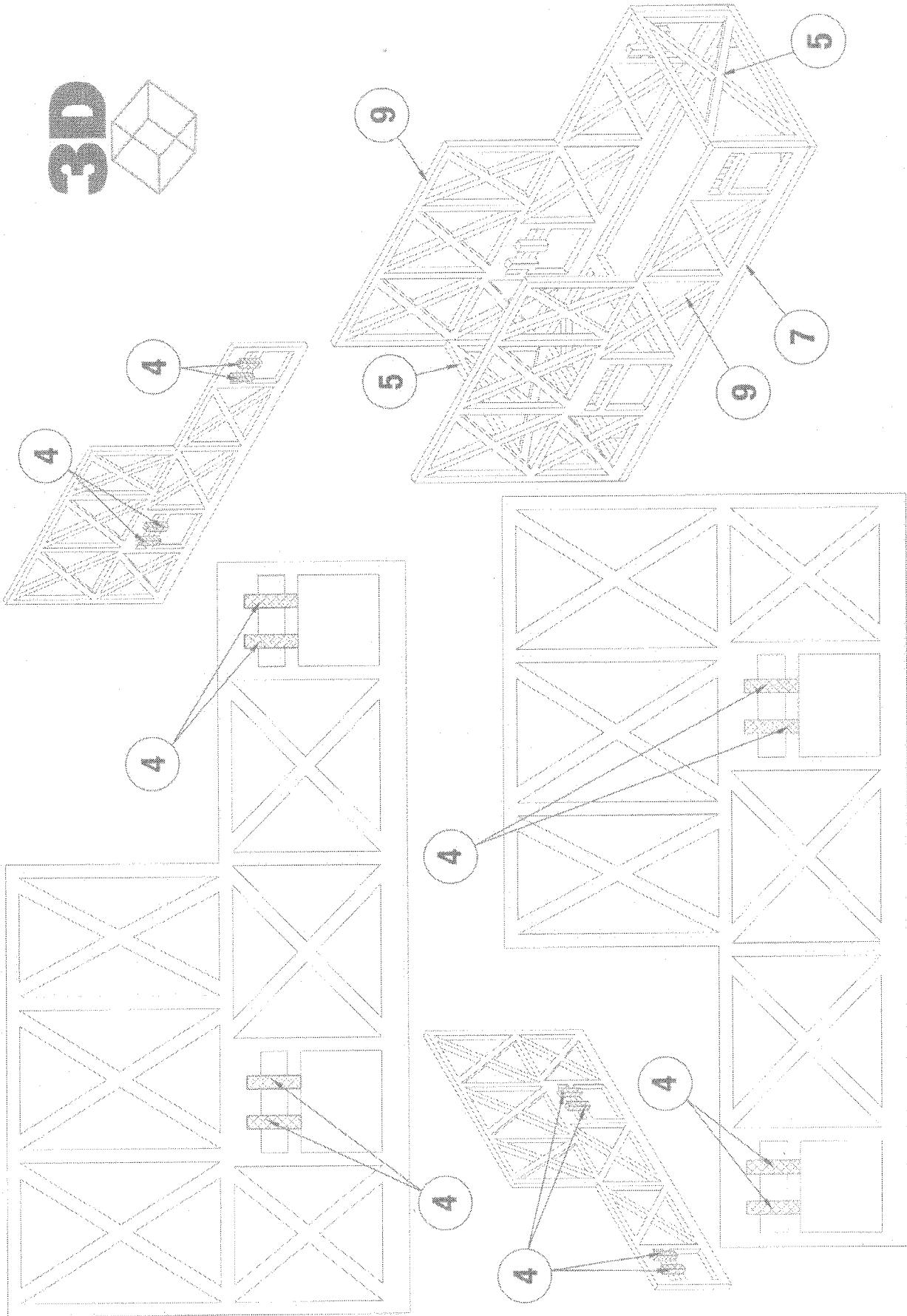

© 2004 Bojox, Inc.

[www.matchitecture.com](http://www.matchitecture.com)

**MATCHITECTURE**

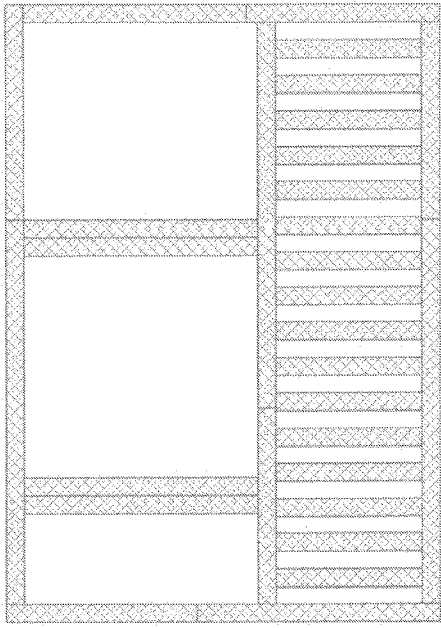

**3D**

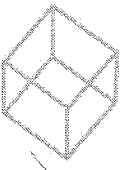

2x13

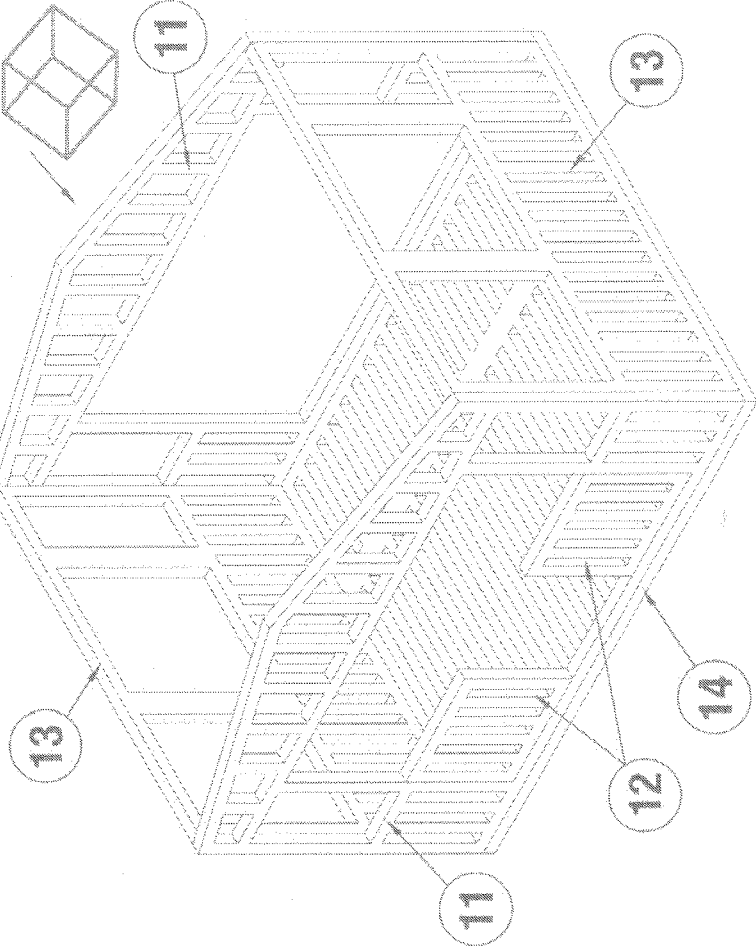

13

11

13

14

12

11

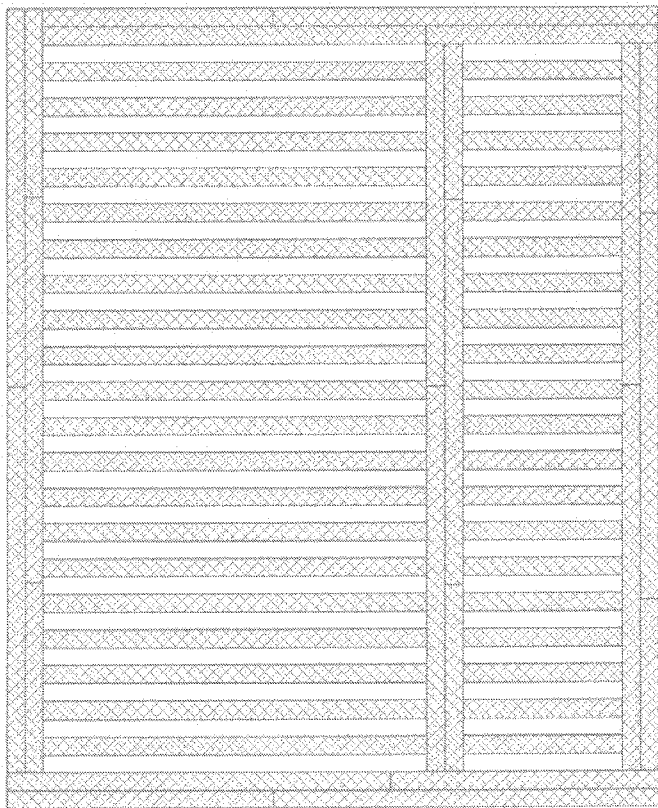

2x15

14

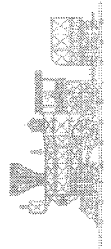
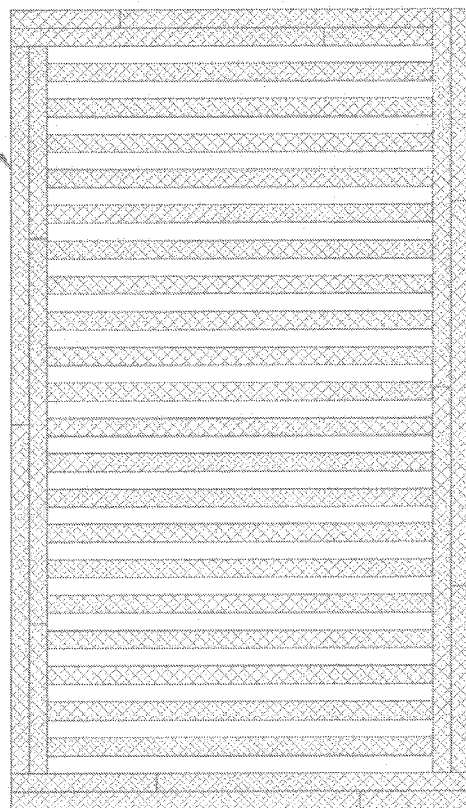

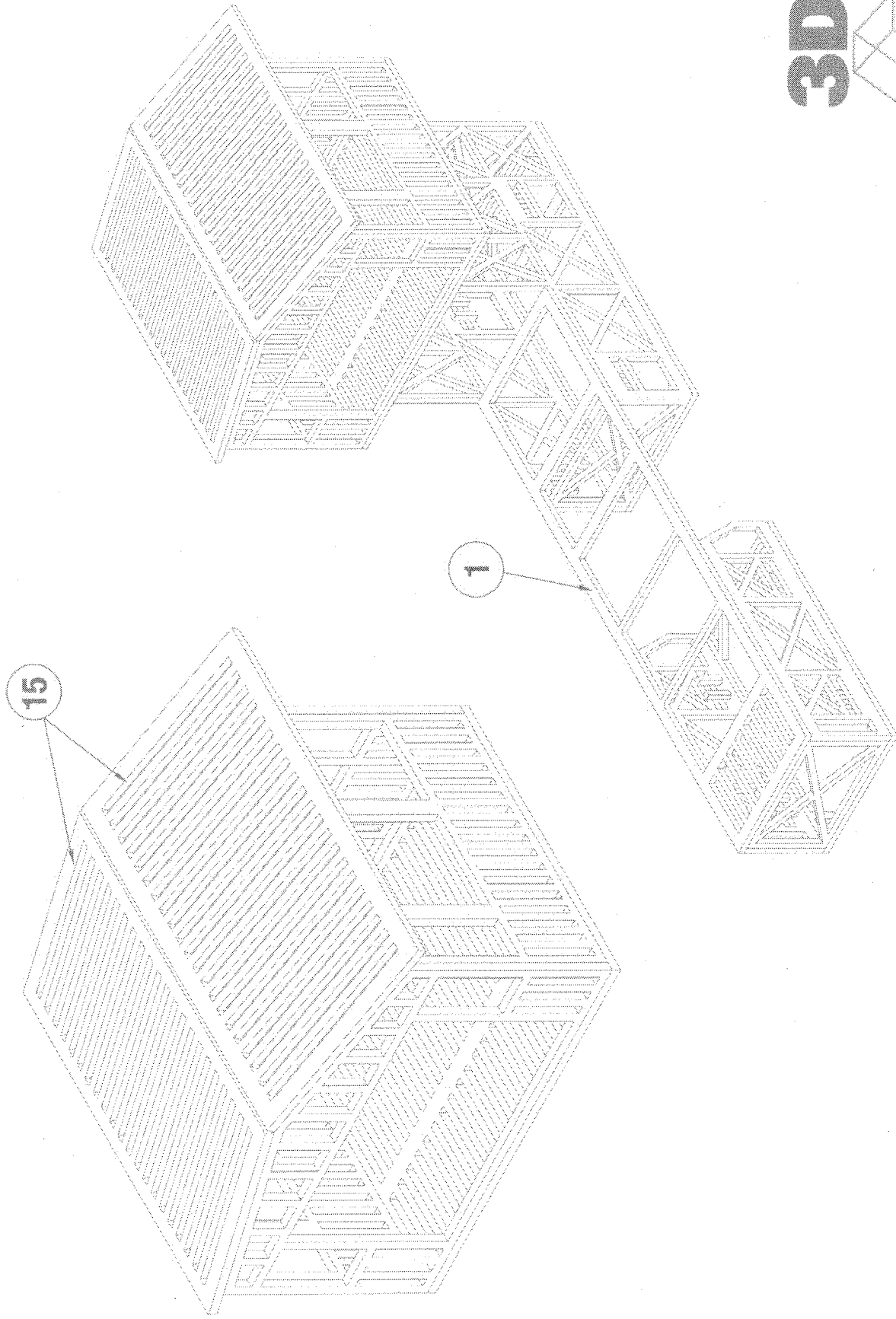

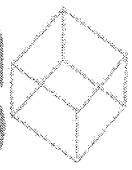
**3D** 

**MArchITECTURE**



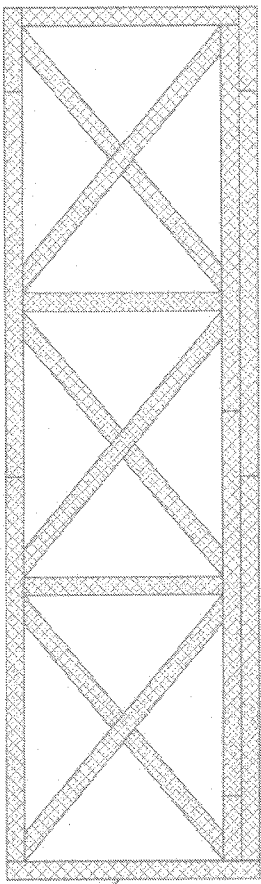

4x 18

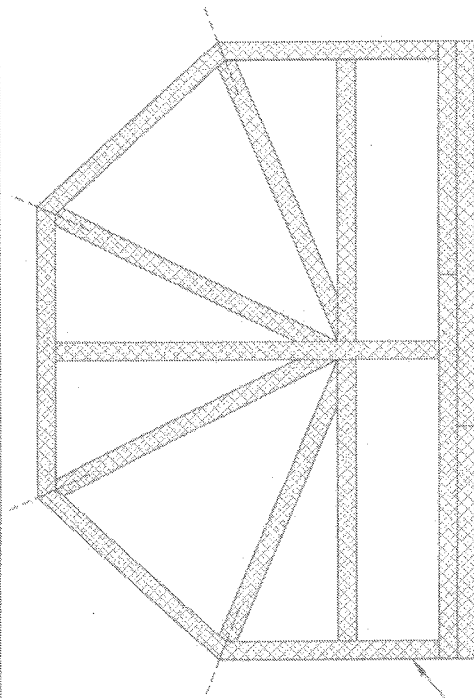
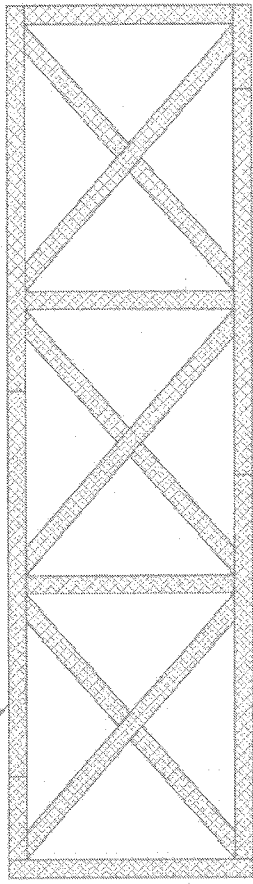

2x 17

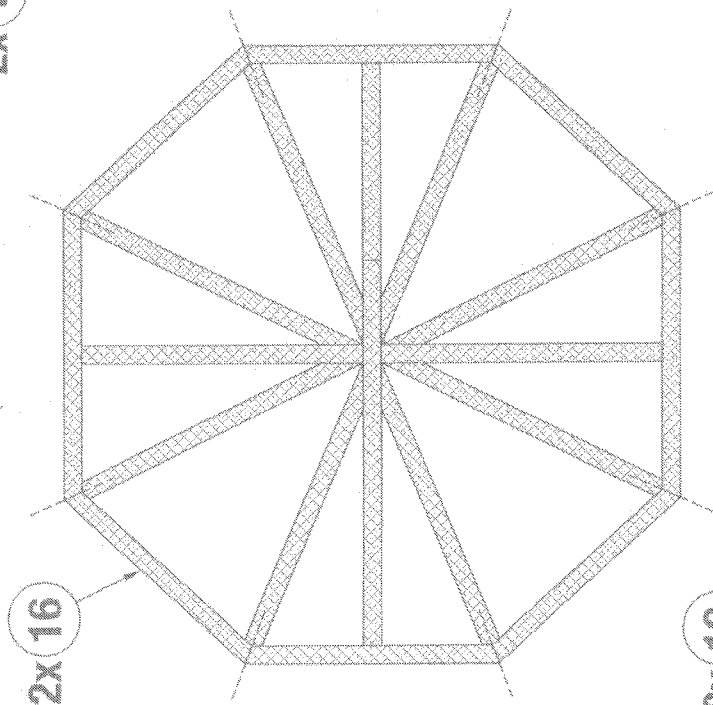

2x 16

2x 20

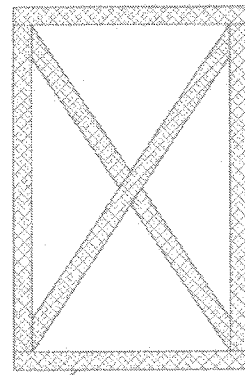

3x 19

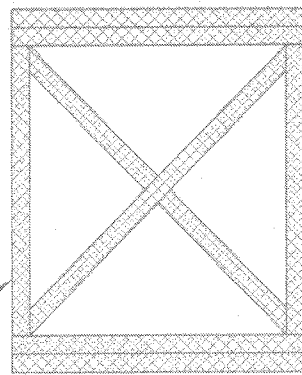

21



© 2004 Egores Inc.

www.matchitecture.com

MATCHITECTURE

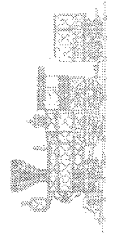
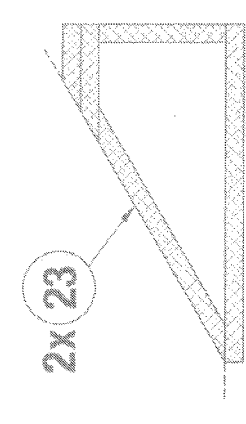
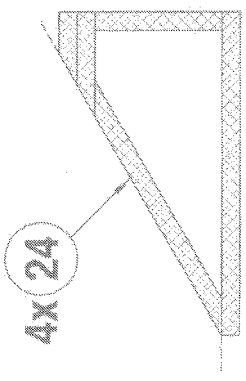
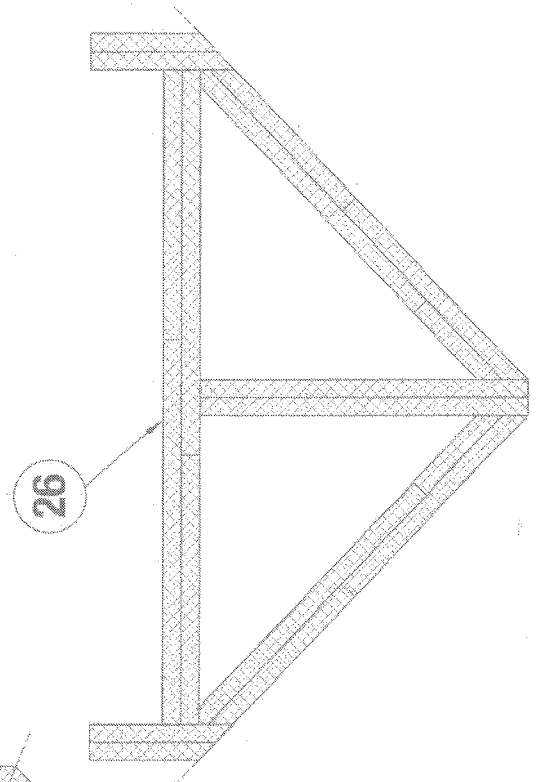
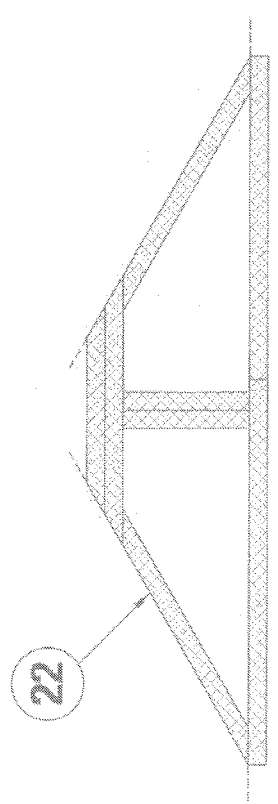
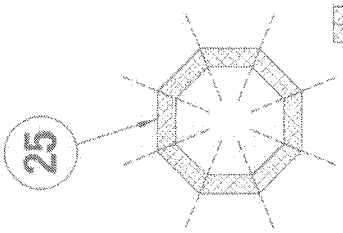
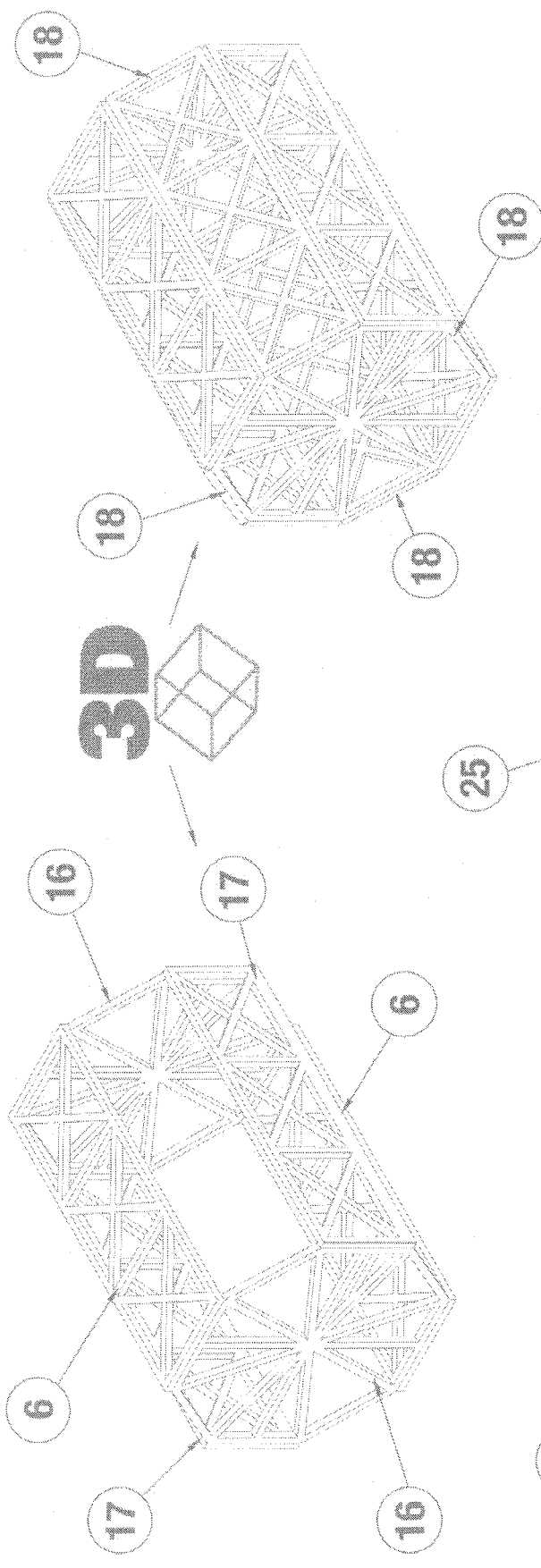

© 2004 Blyskal, Inc.

www.ma4chitecture.com

MA4CHITECTURE

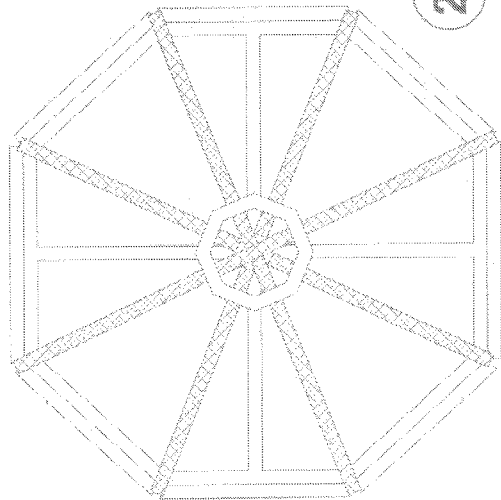
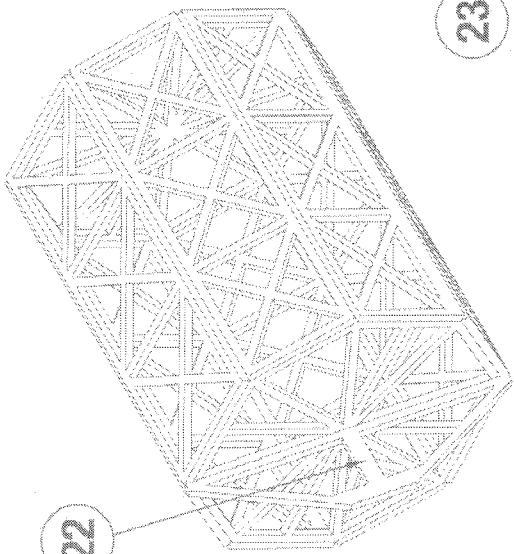
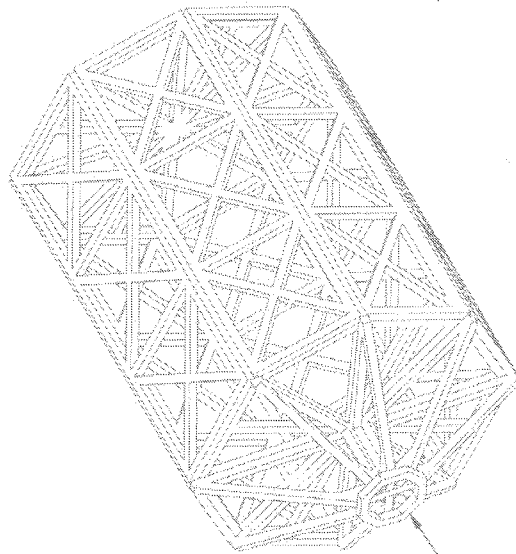
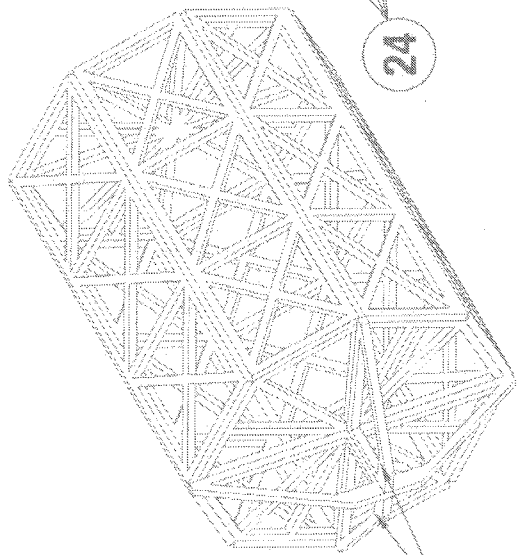
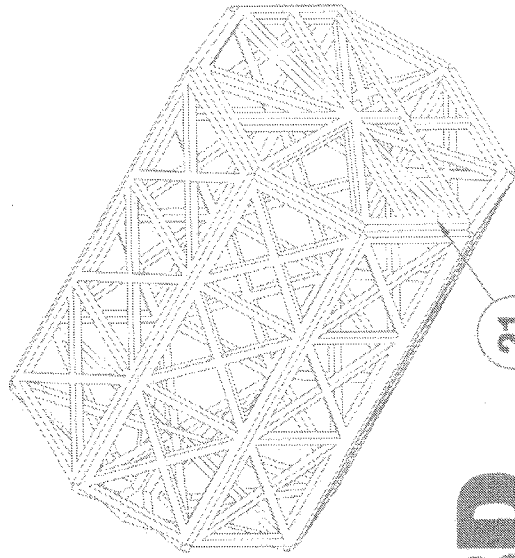
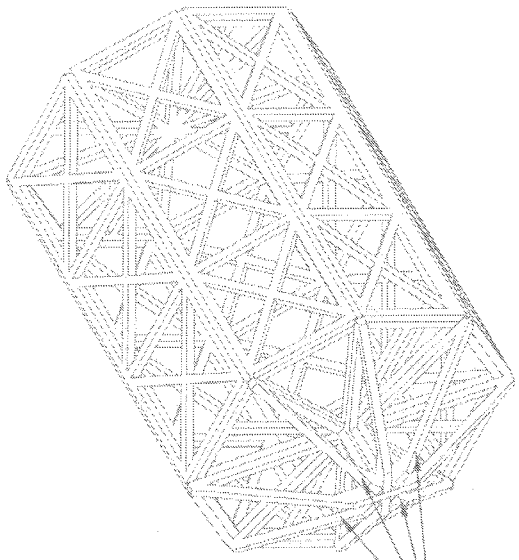

**3D**

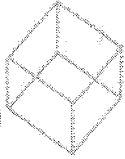

© 2004 Bejoux, Inc.

[www.matchitecture.com](http://www.matchitecture.com)

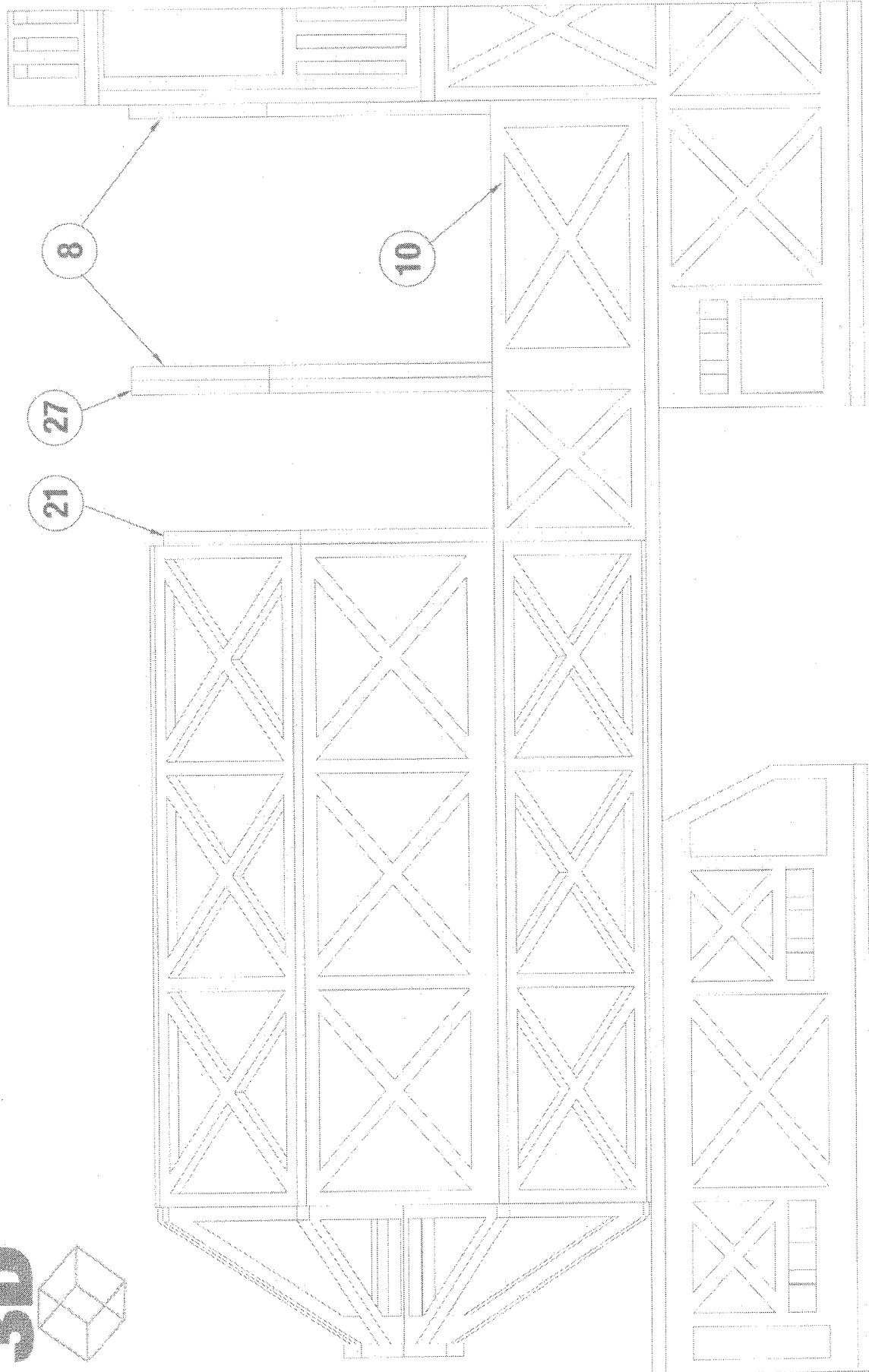
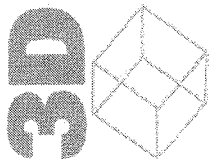

© 2004 Boeub, Inc.

[www.machitecture.com](http://www.machitecture.com)

MACHITECTURE

10 739

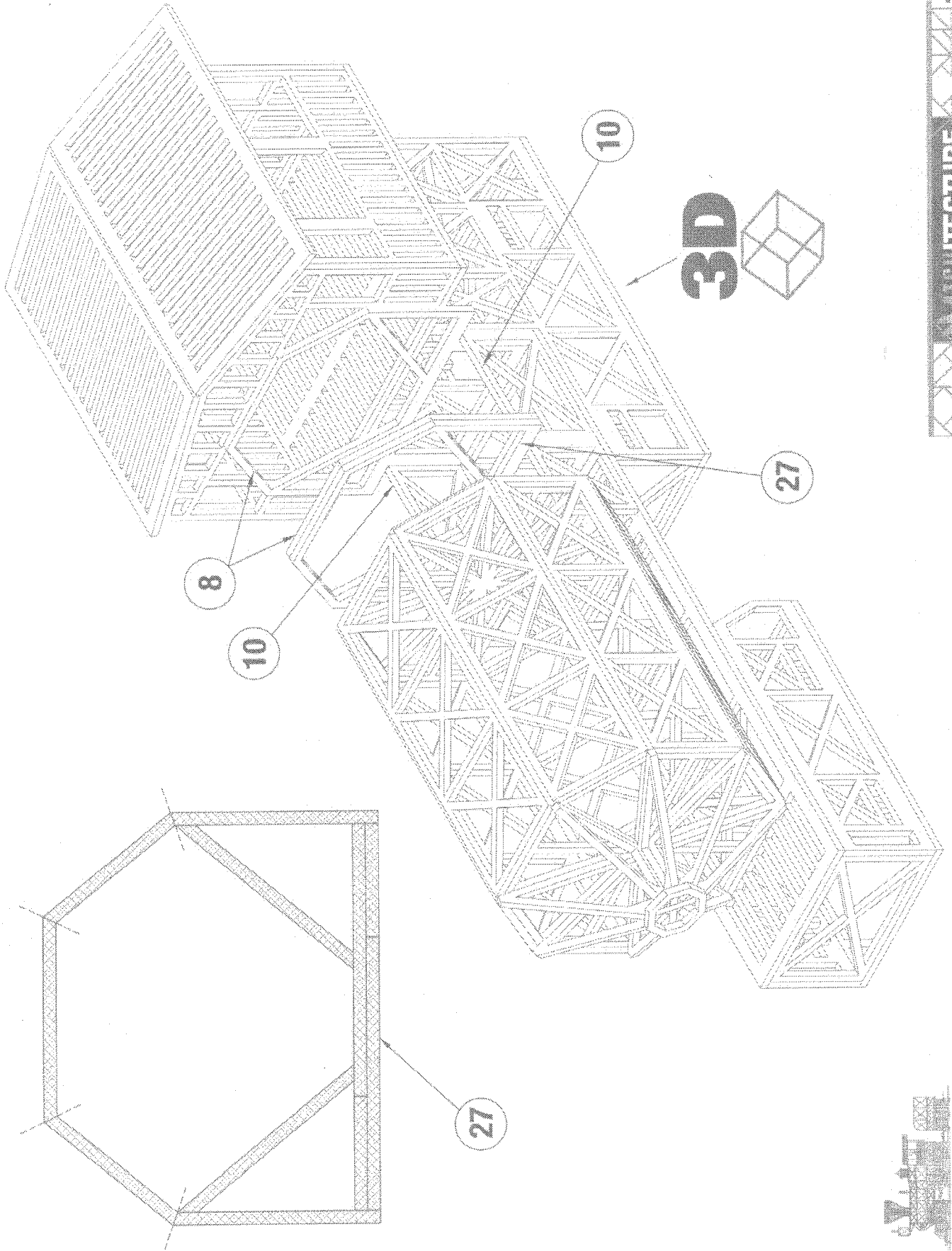

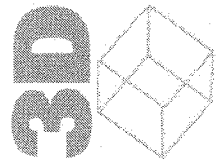
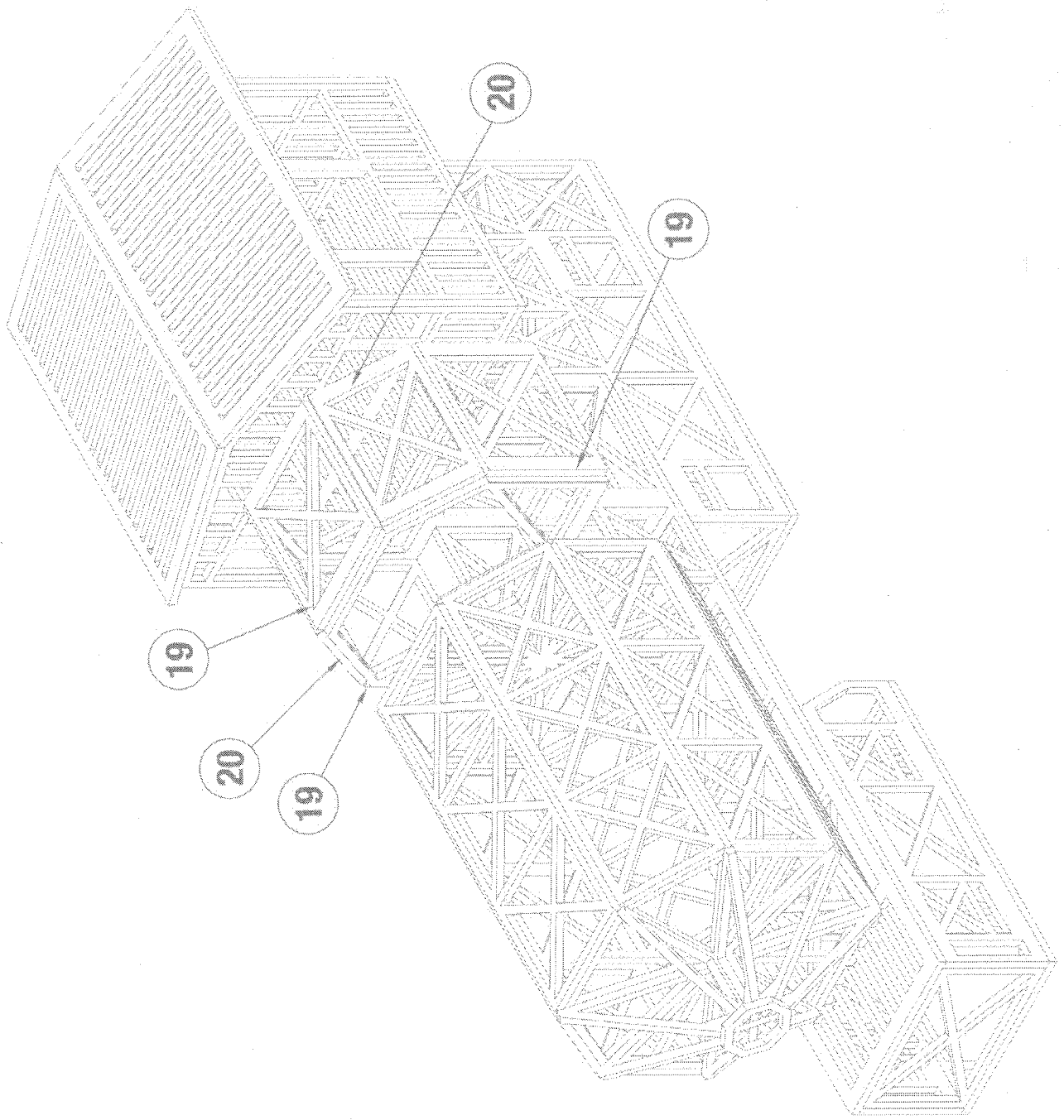

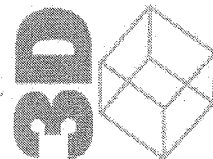
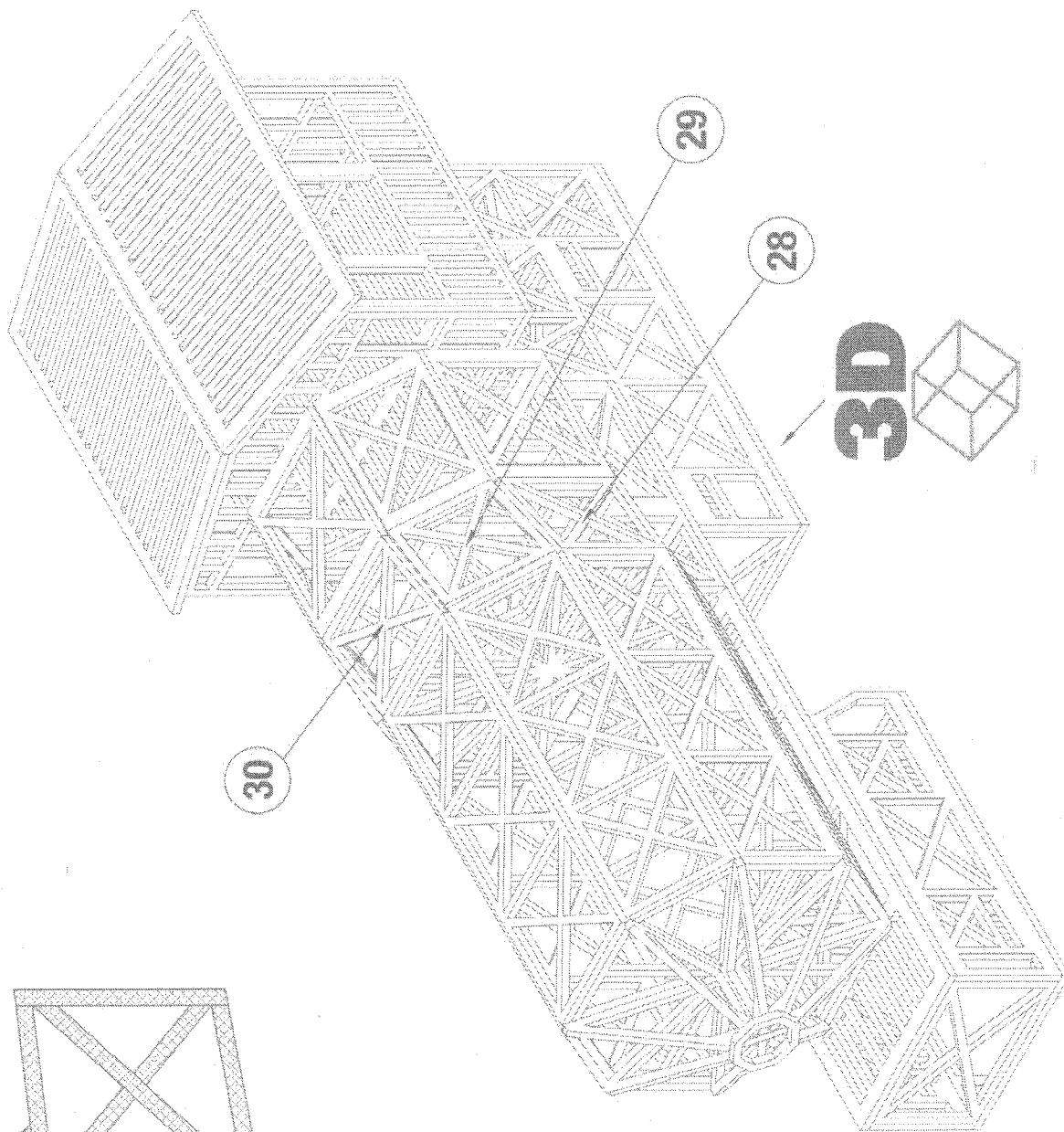
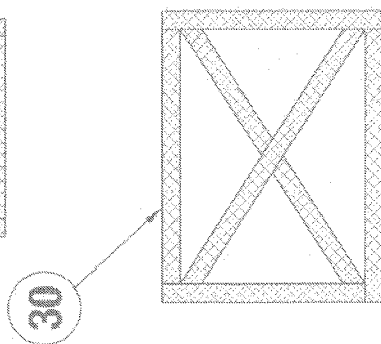
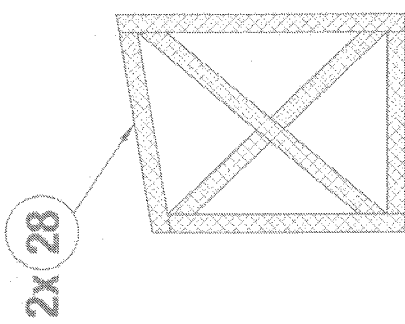
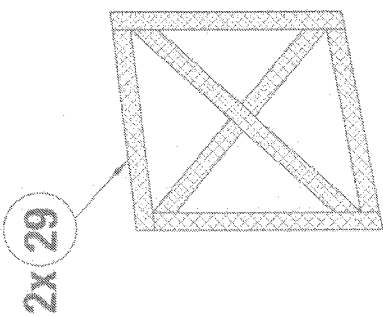

**3D**

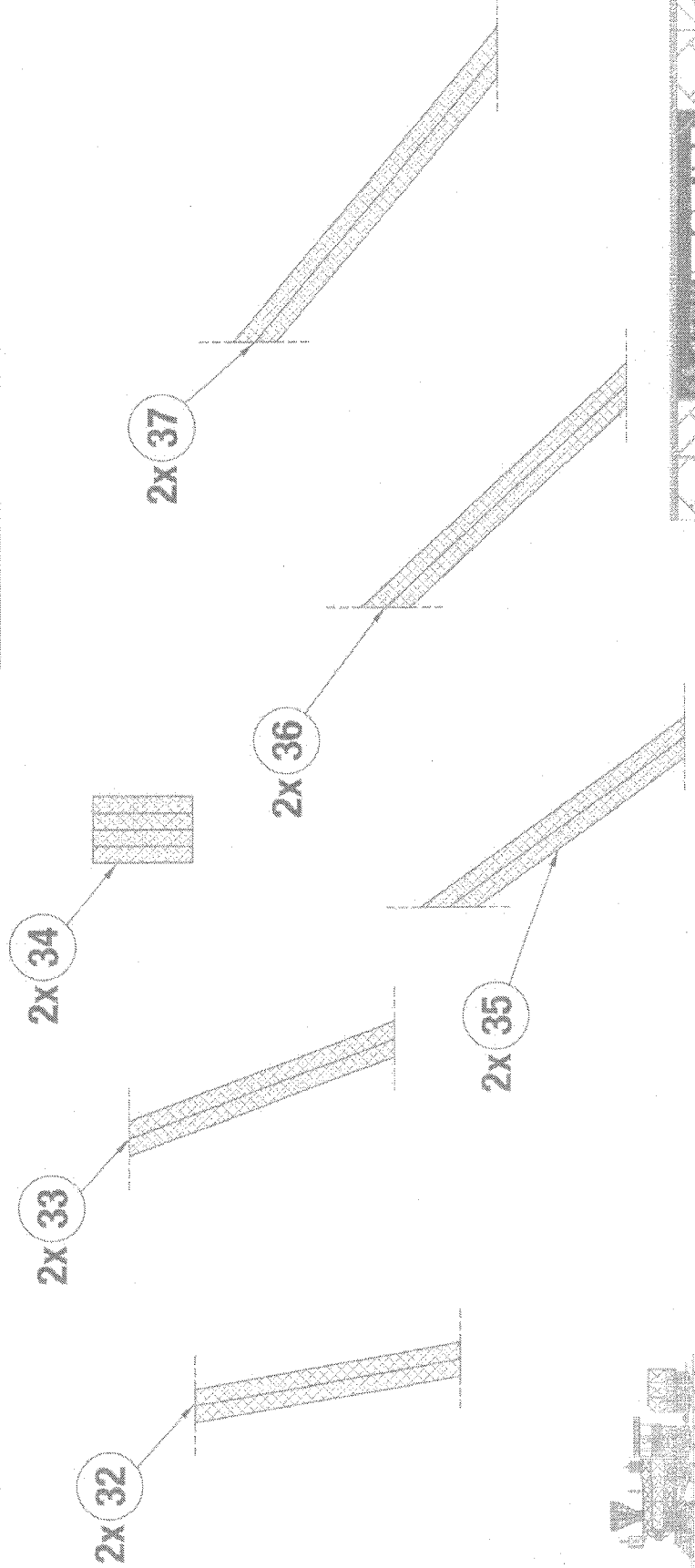
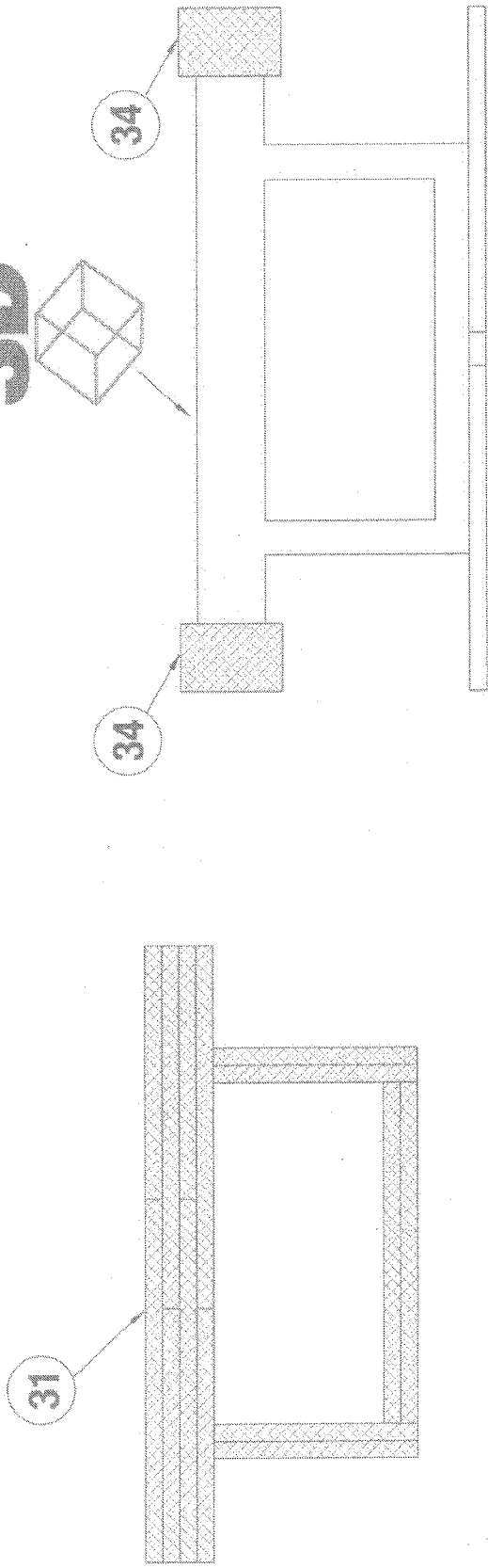

© 2004 B&J Inc.

[www.matchitecture.com](http://www.matchitecture.com)

**MATCHITECTURE**

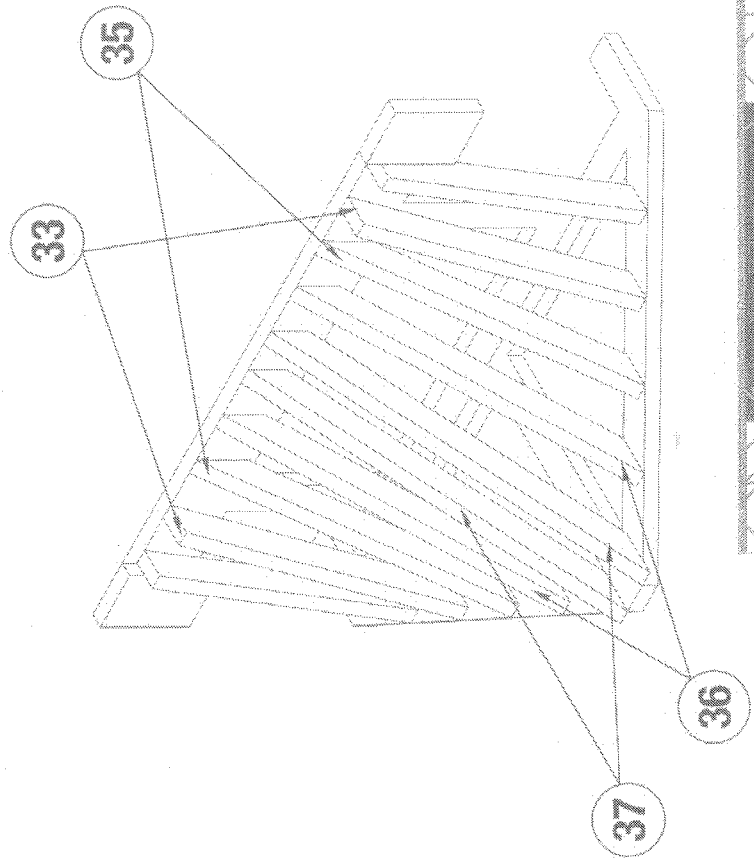
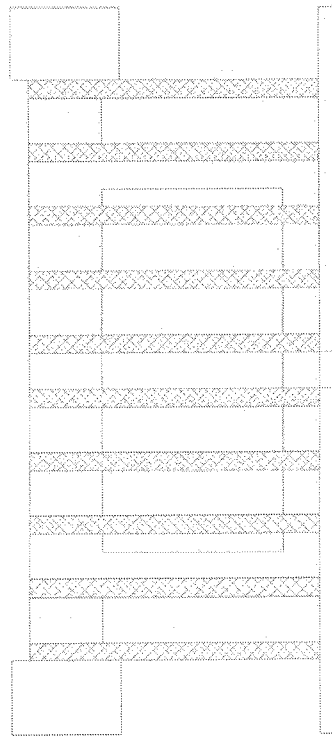
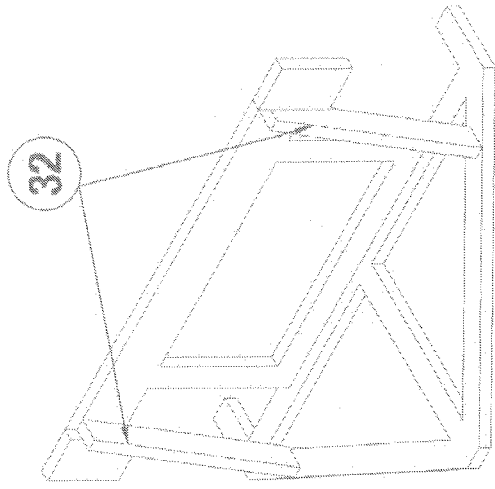
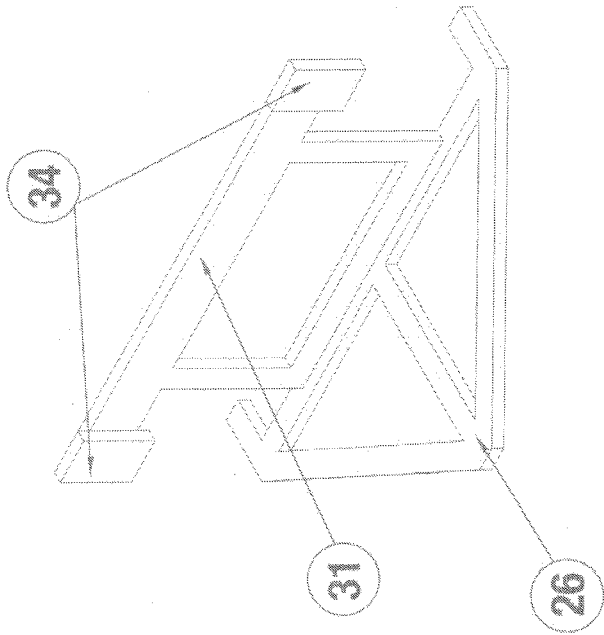
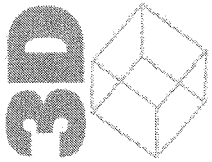

© 2004 Bopex Inc.

[www.matchitecture.com](http://www.matchitecture.com)

Matchitecture

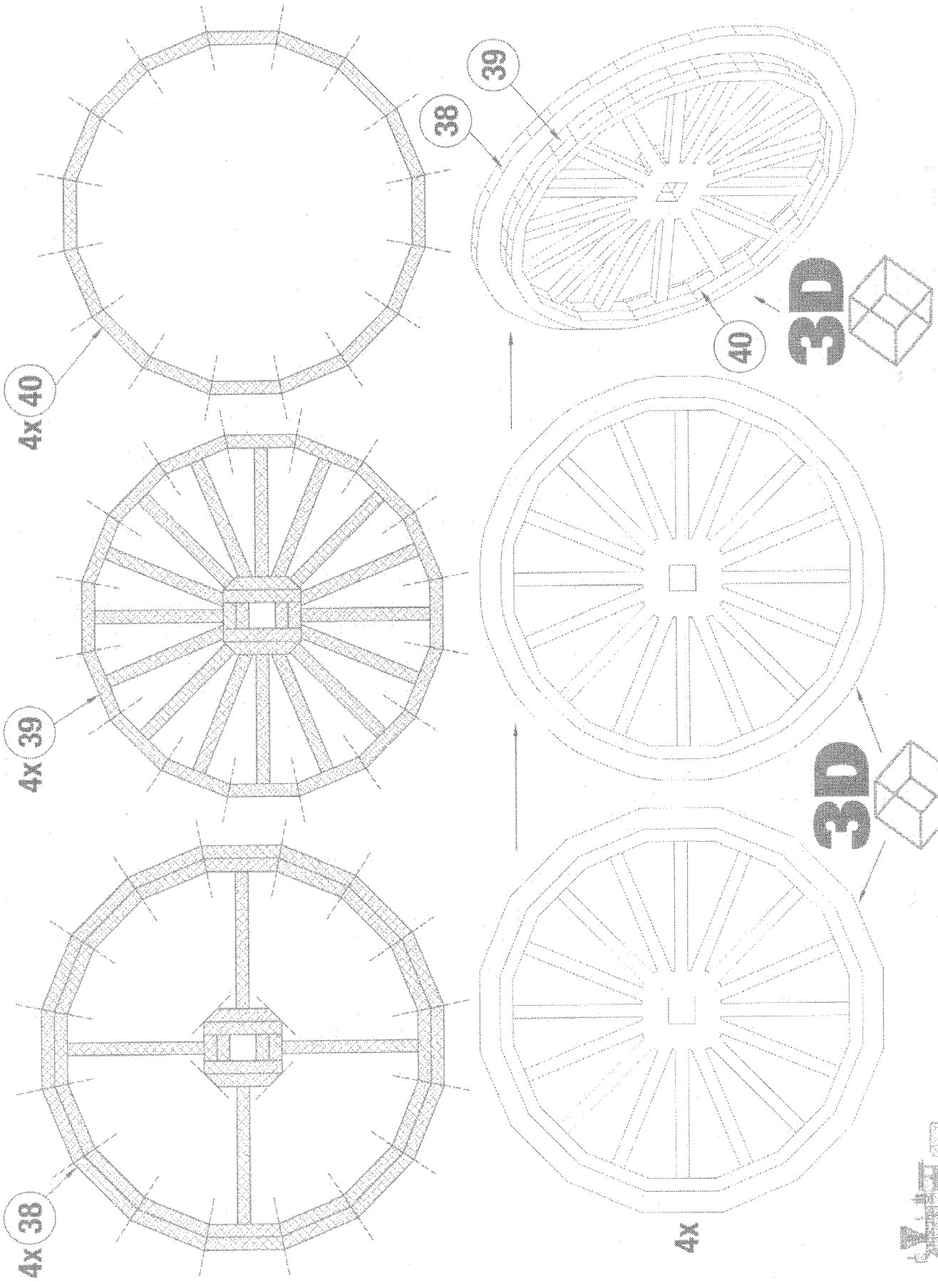
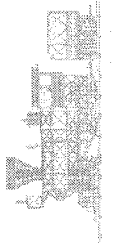

4x 40

4x 39

4x 38

38

39

40

3D

3D

4x

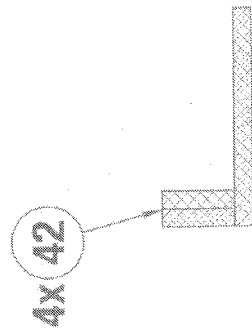
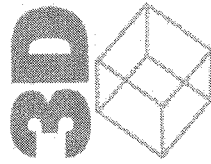
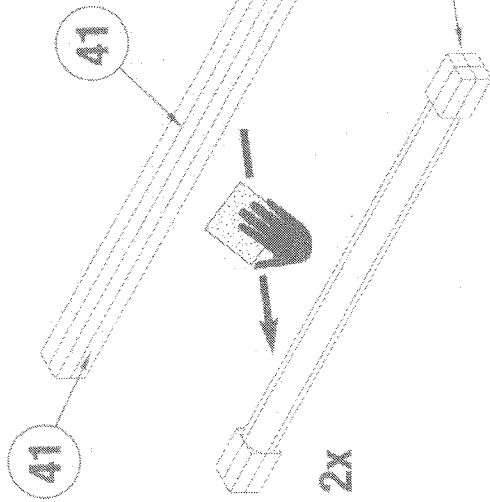
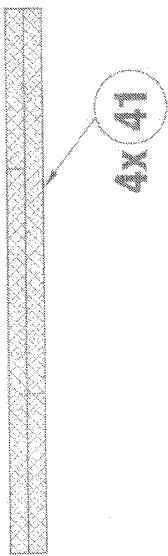
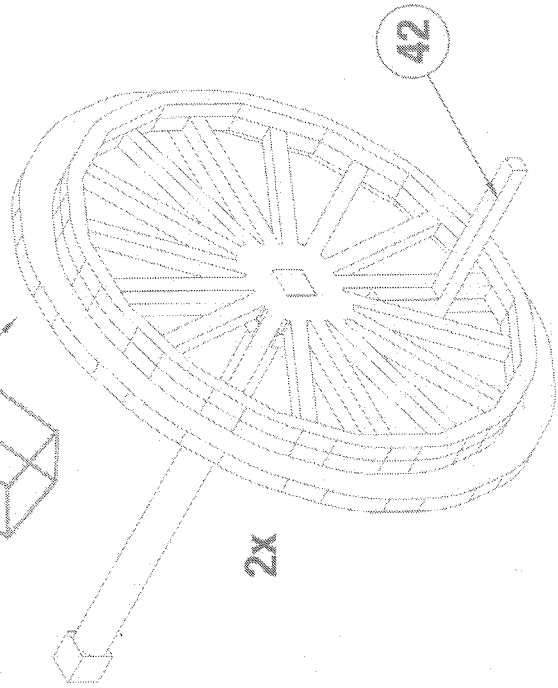
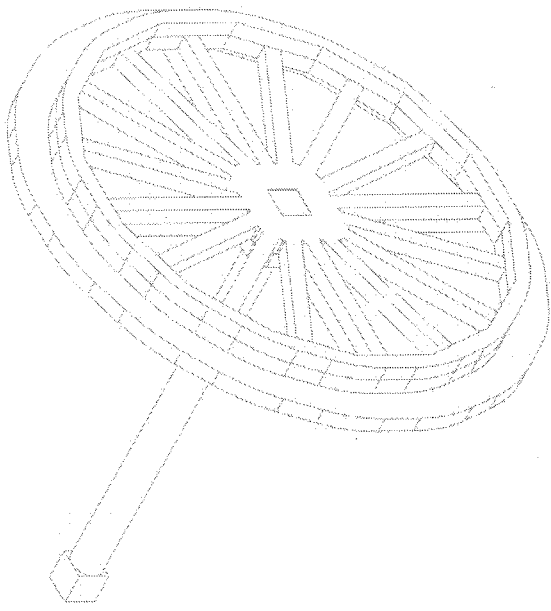

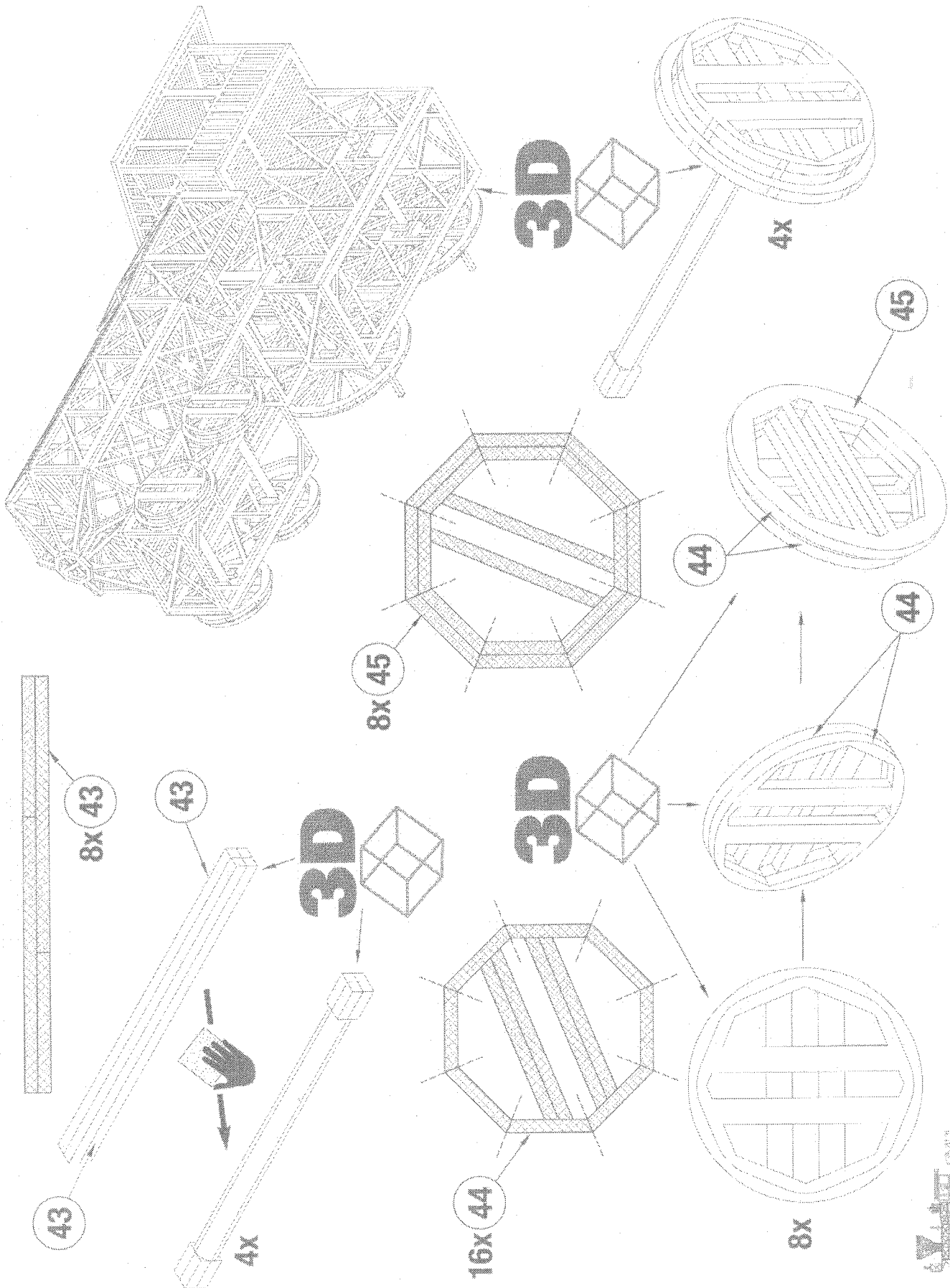

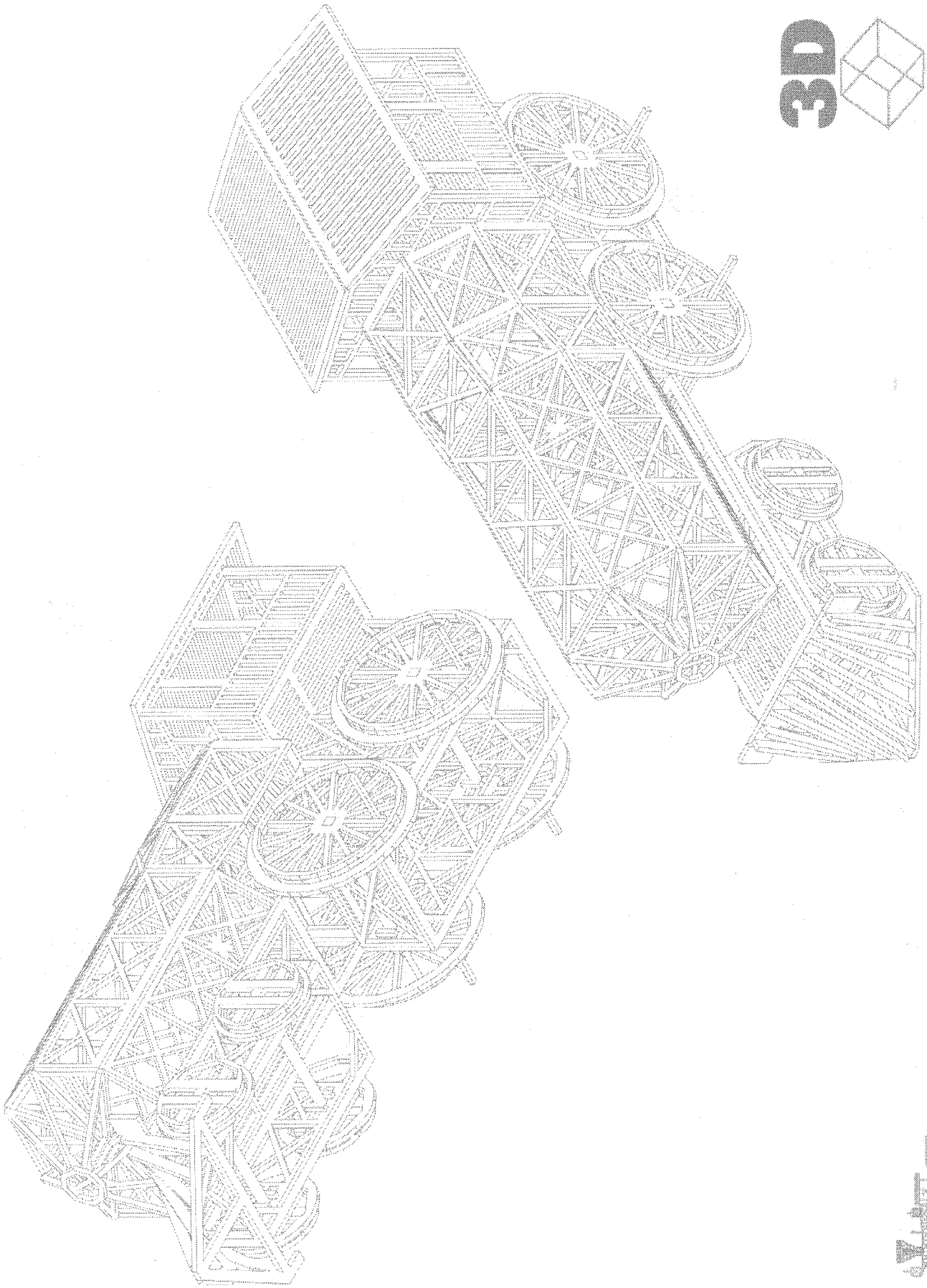

**3D**

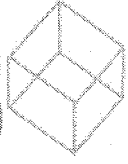

2x 49

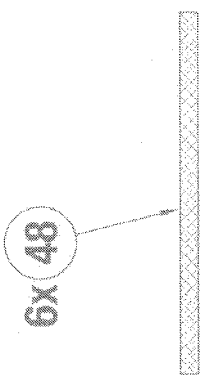

6x 48

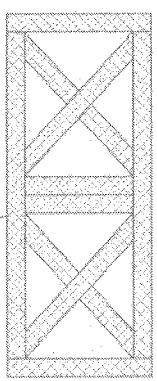

8x 47

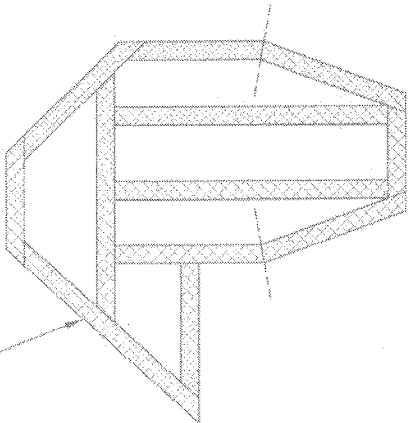

4x 46

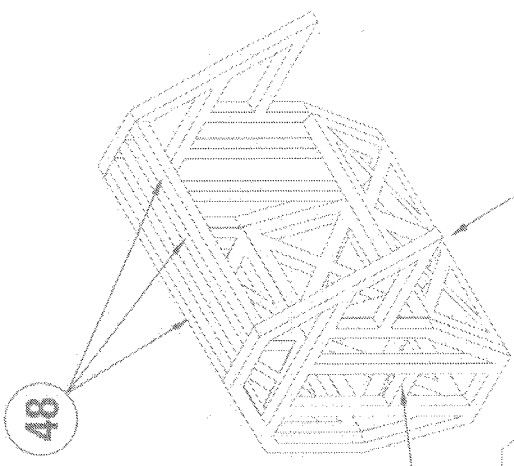

48

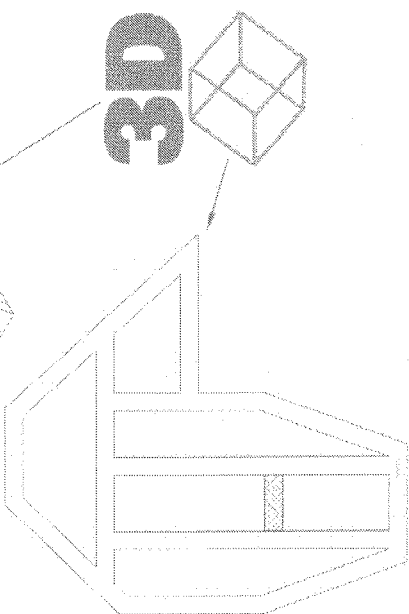

46

2x

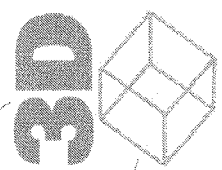

3D

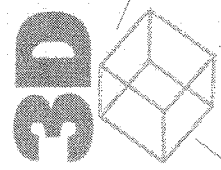
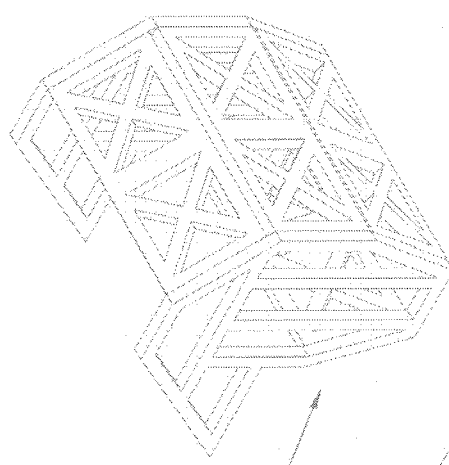

3D

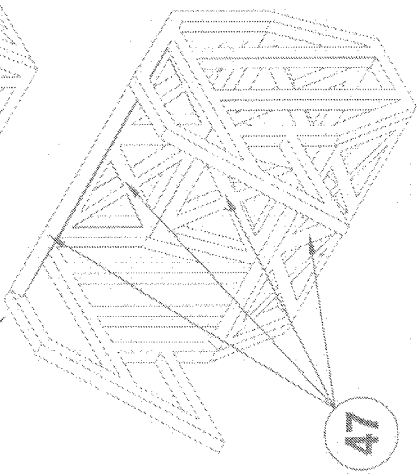

47

46

47



© XGO2 Bojars, Inc.

www.matchitecture.com

MATCHITECTURE

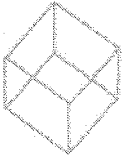
**3D** 

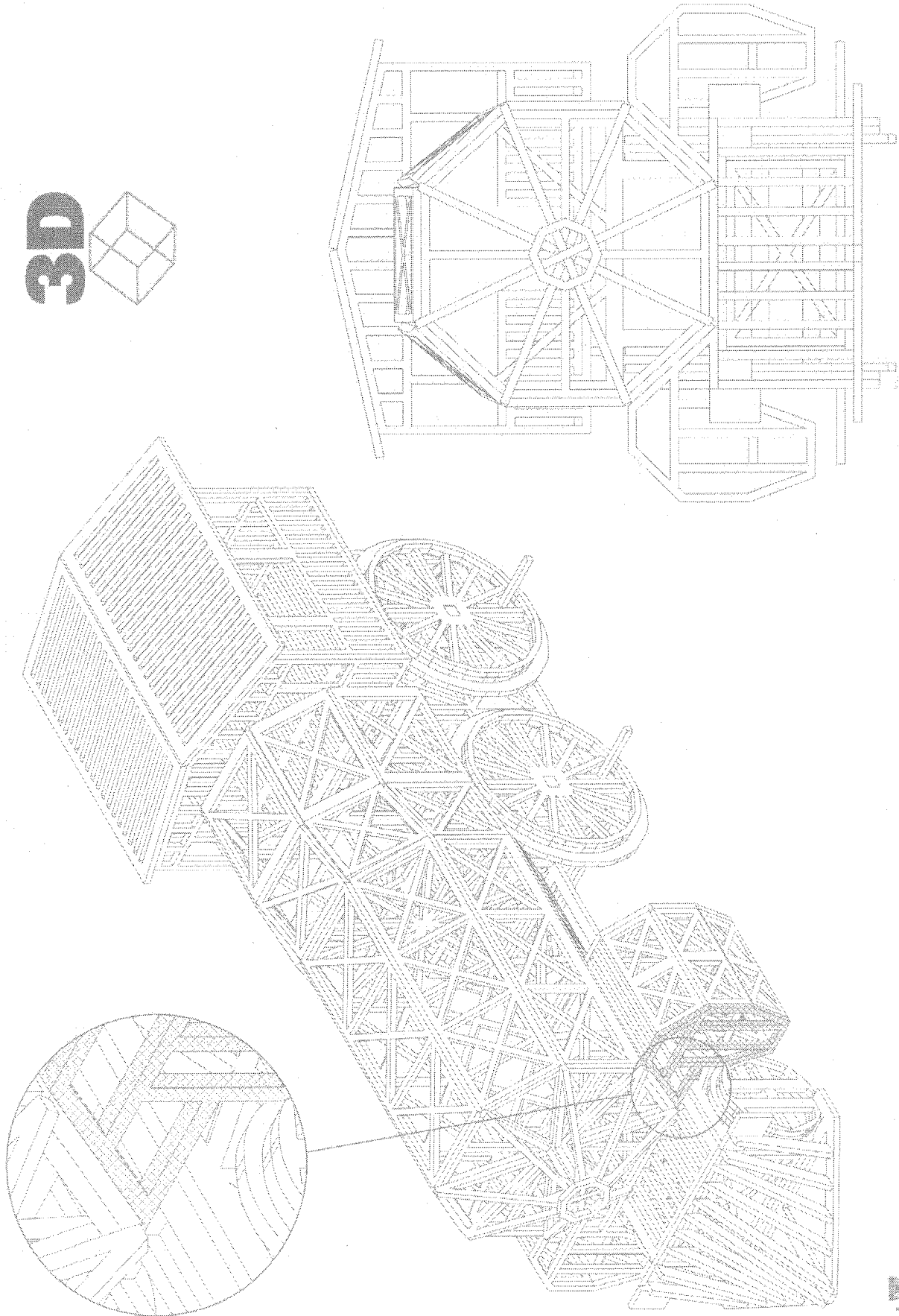

© 2004 Boleax, Inc.

[www.matchitecture.com](http://www.matchitecture.com)

**ARCHITECTURE**

**21** / 39

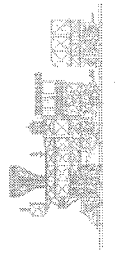
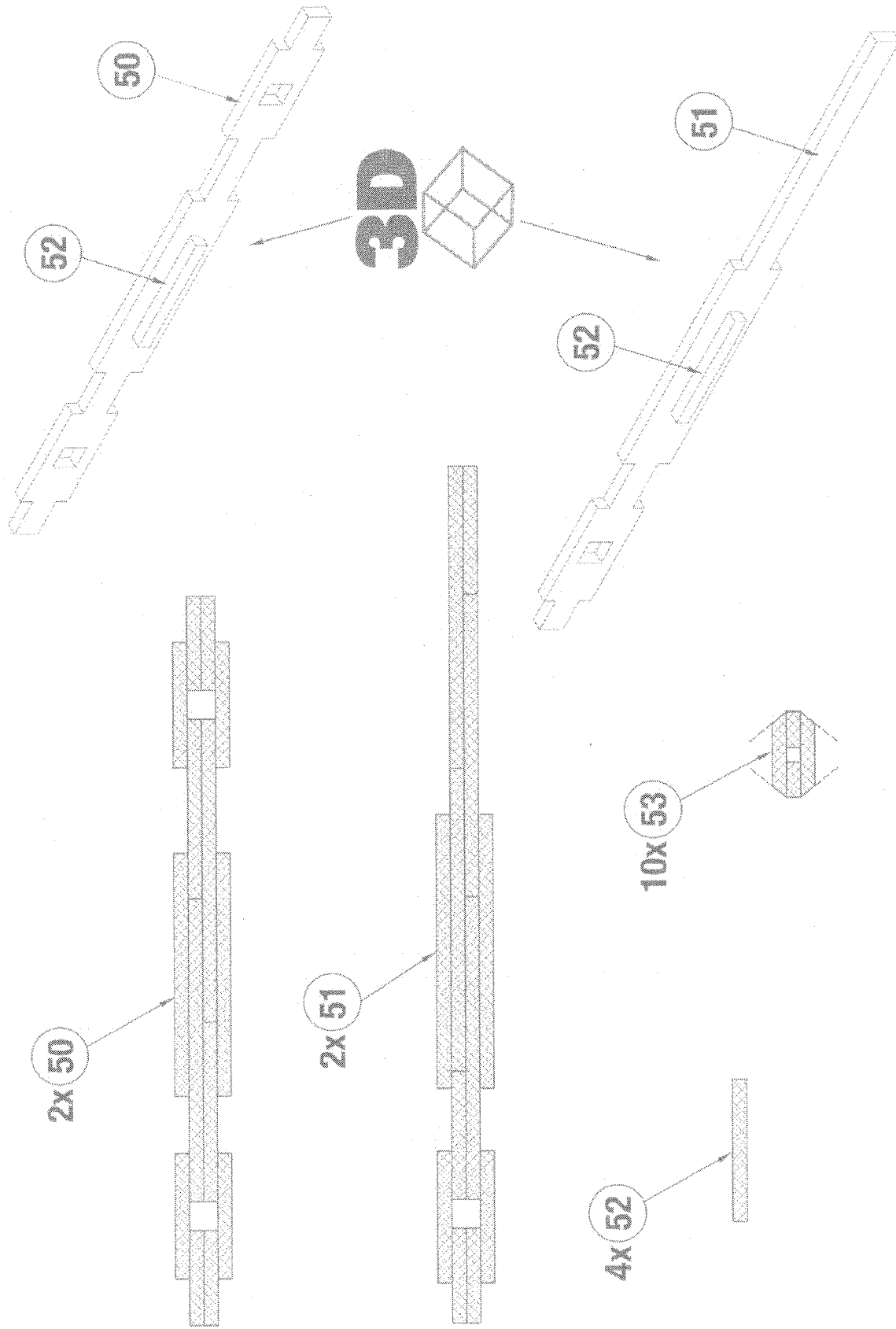

© 2004 Repaix Inc.

www.matchitecture.com

ARCHITECTURE

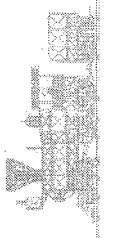
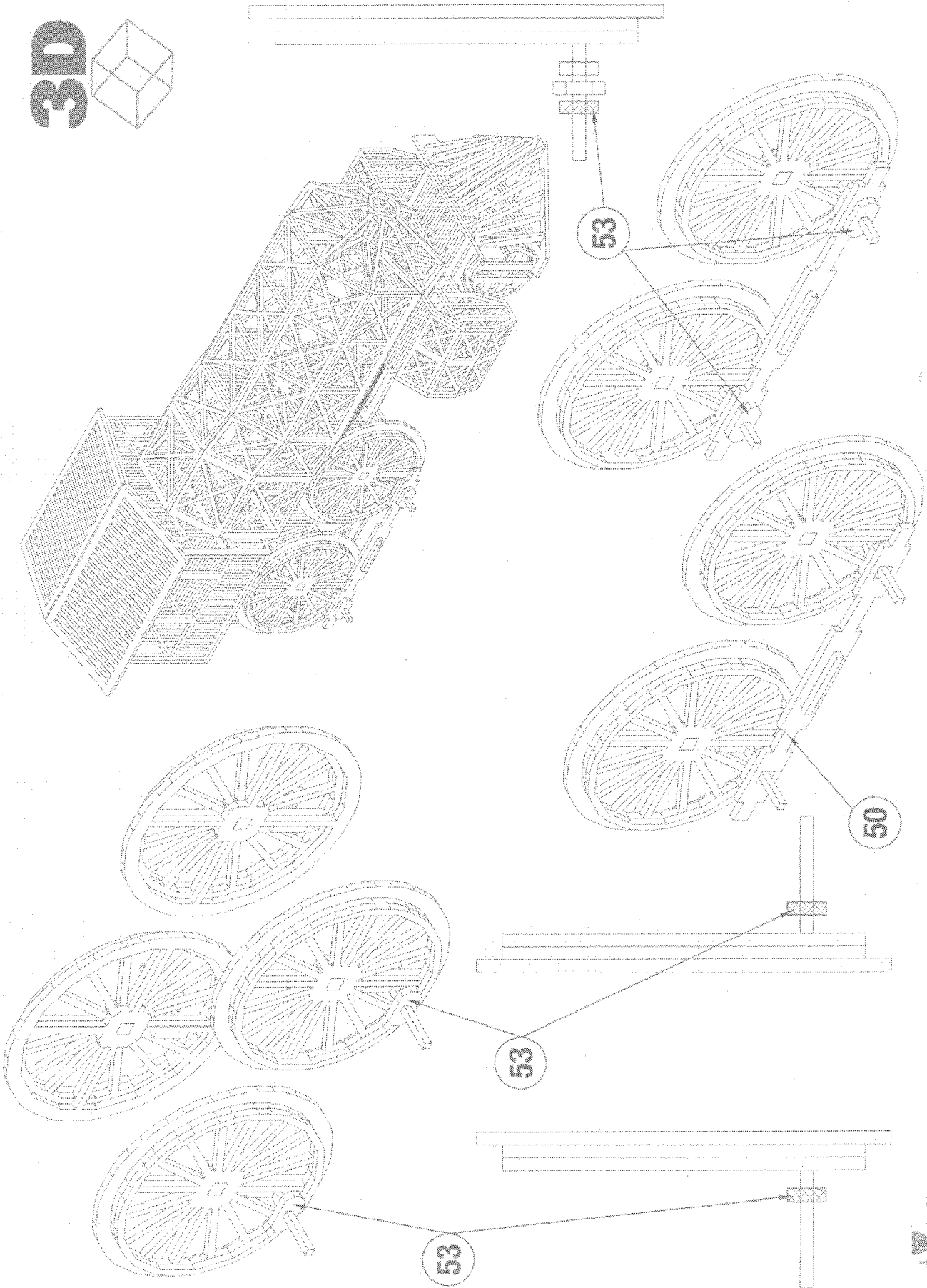
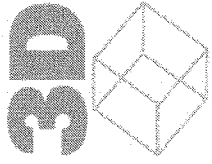

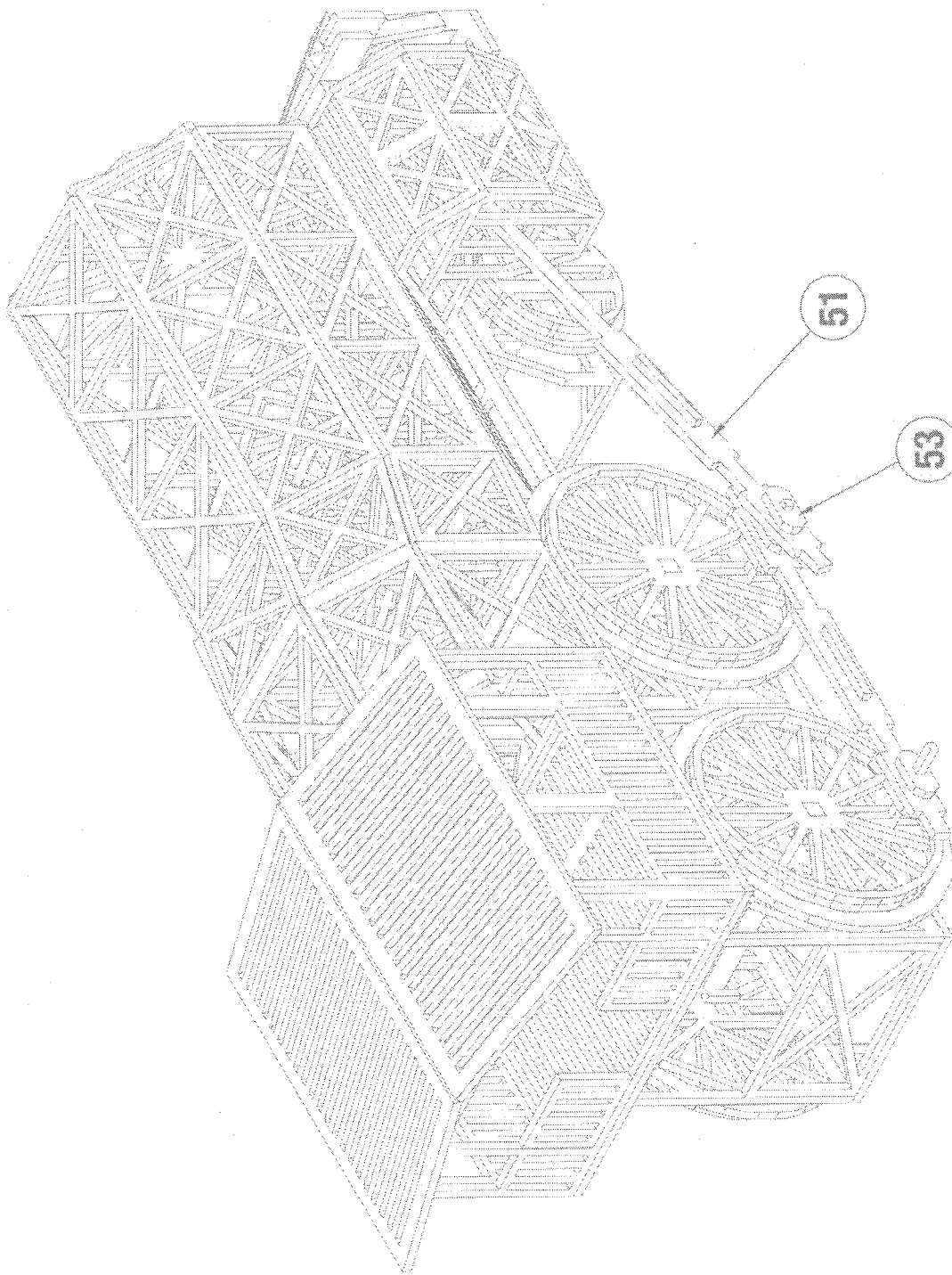

**3D**





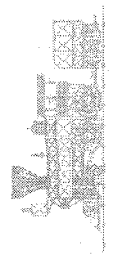
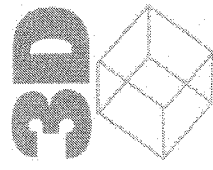
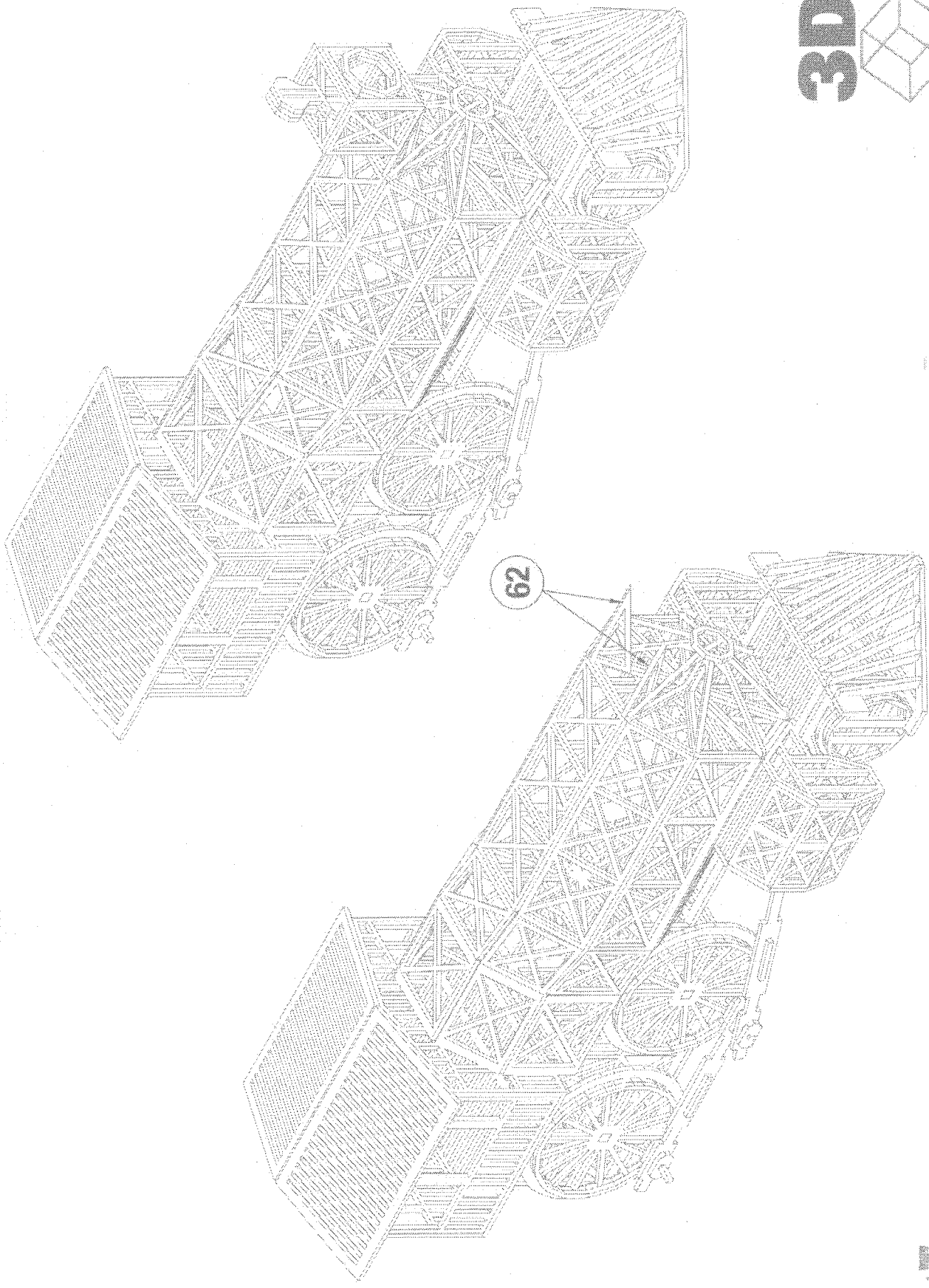

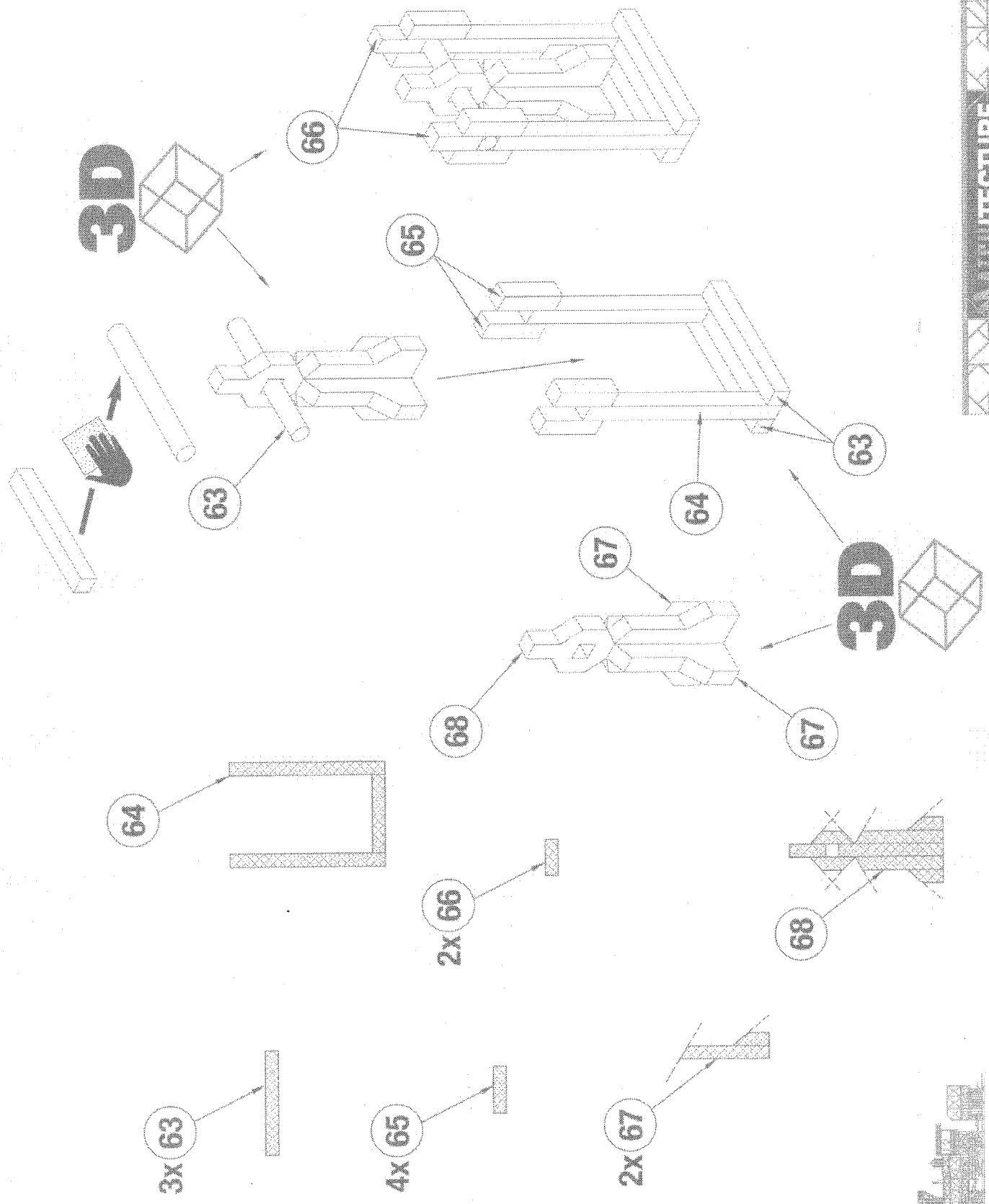

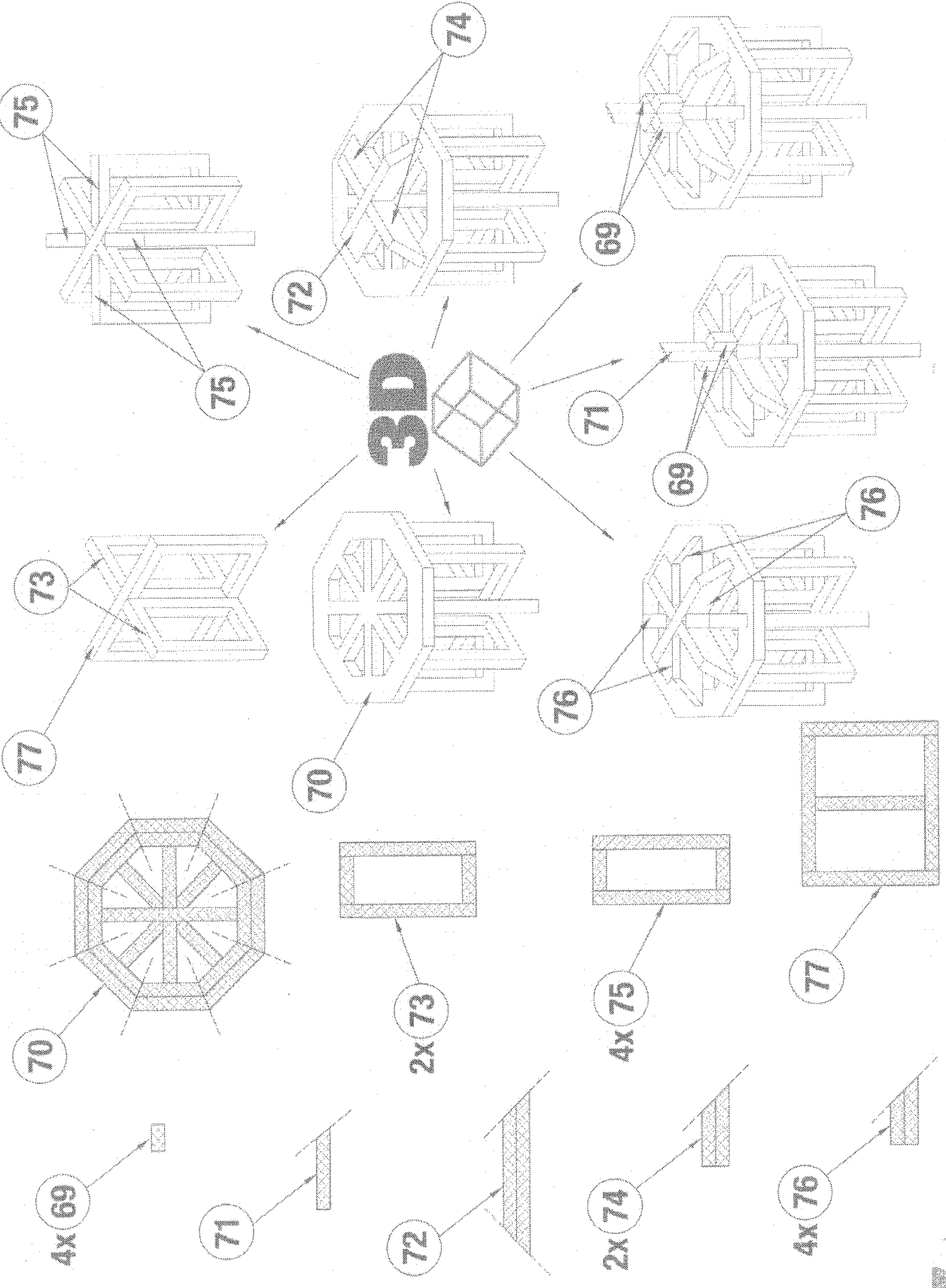

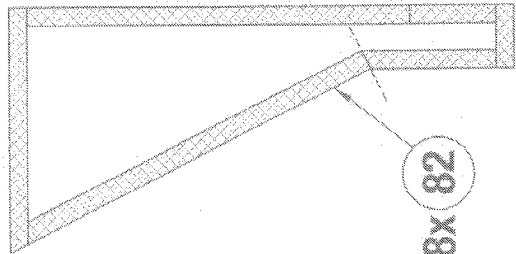

8x 82

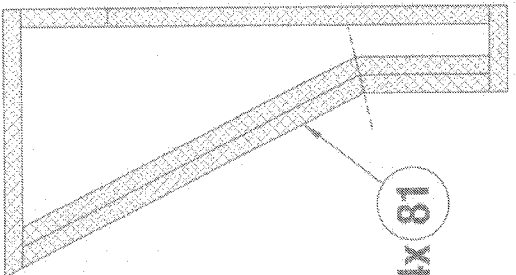

4x 81

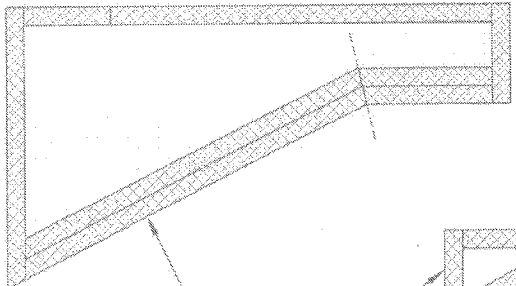

2x 80

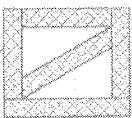

16x 83

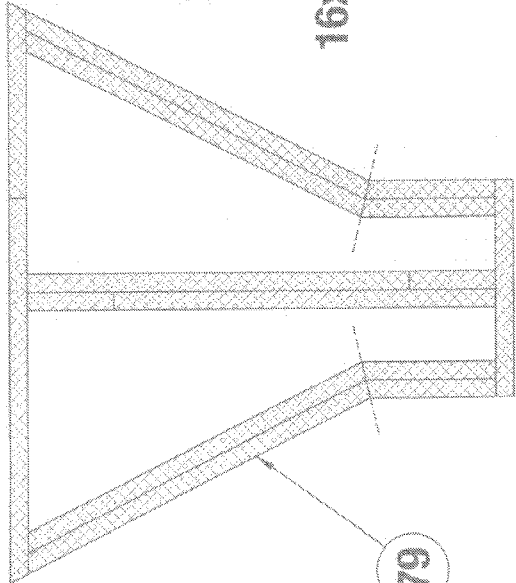

79

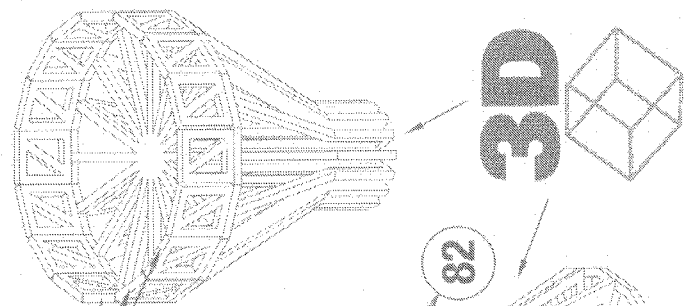

83

81

82

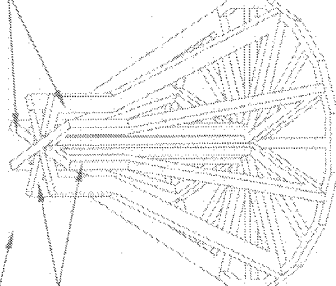

81

80

79

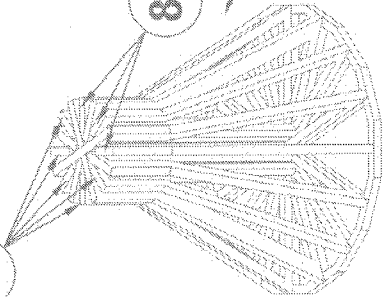

82

3D

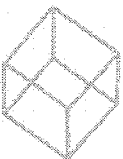

3D

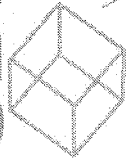

78

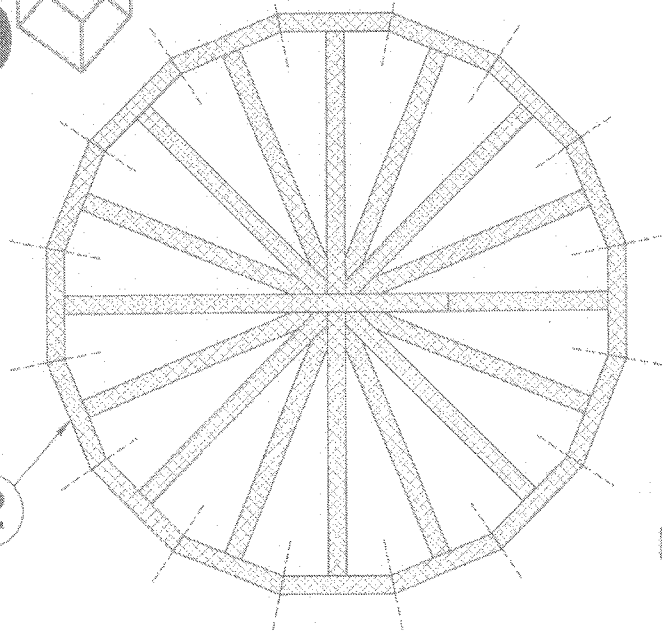

78



© 2004 Bojest Inc.

www.matchitecture.com

MATCHITECTURE

3D

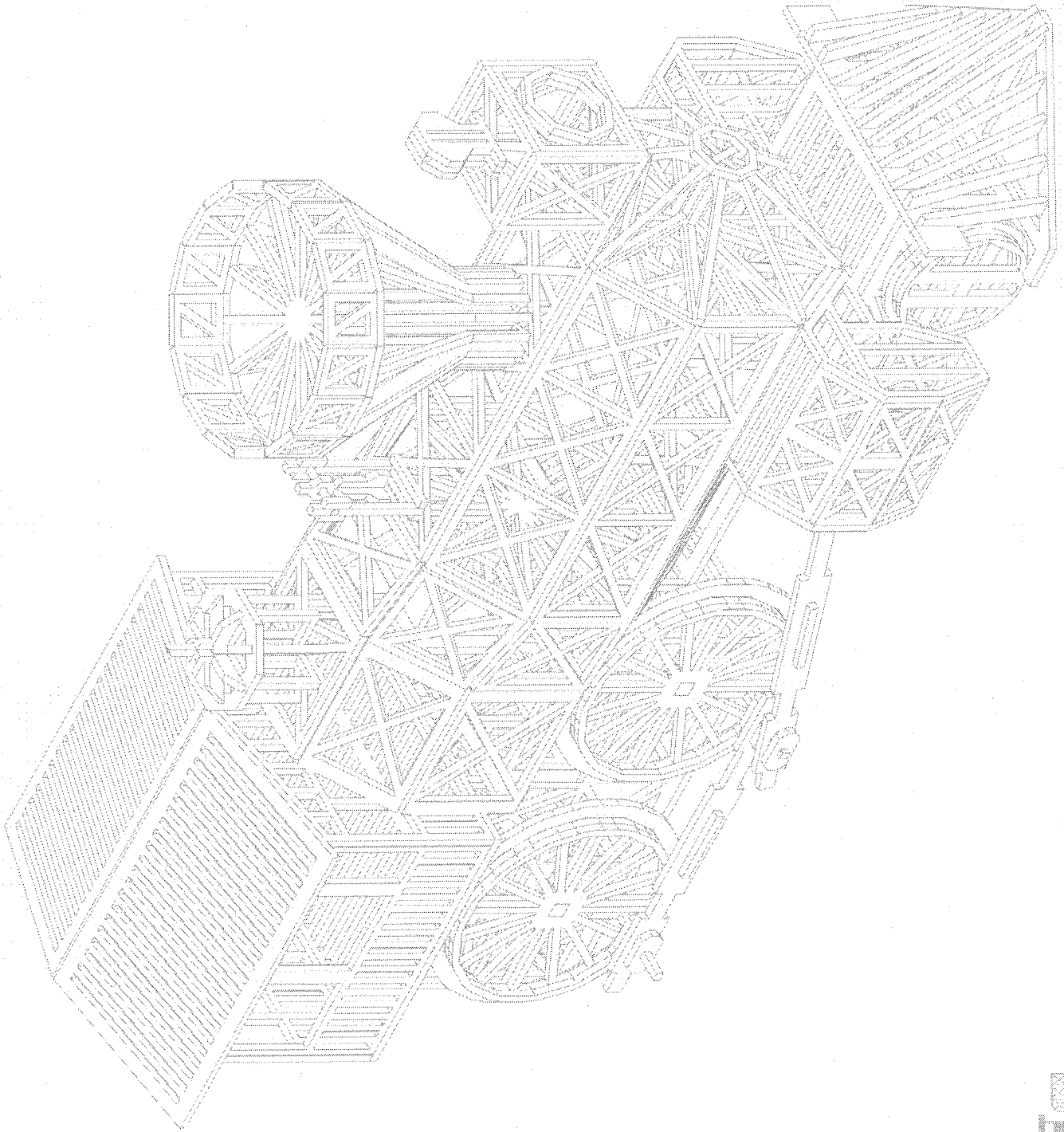

© 2004 Beprix Inc.

[www.matichitecture.com](http://www.matichitecture.com)

ARCHITECTURE

30 / 33

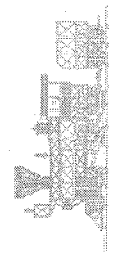
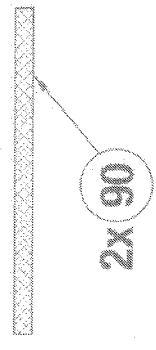
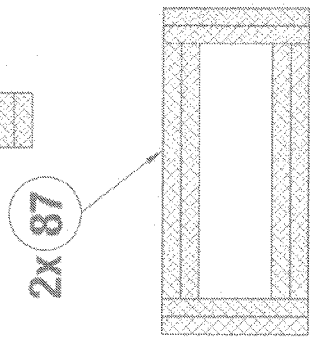
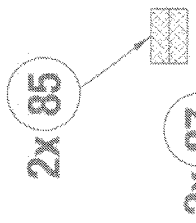
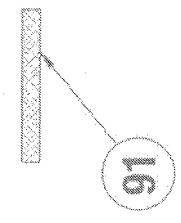
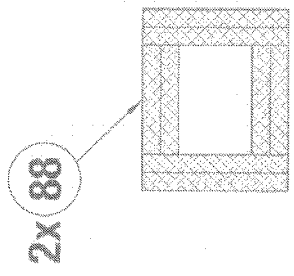
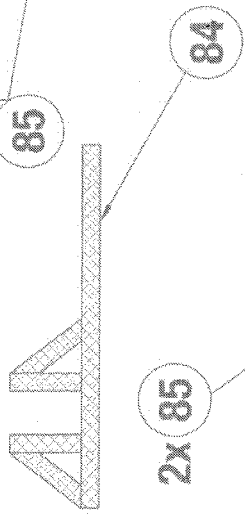
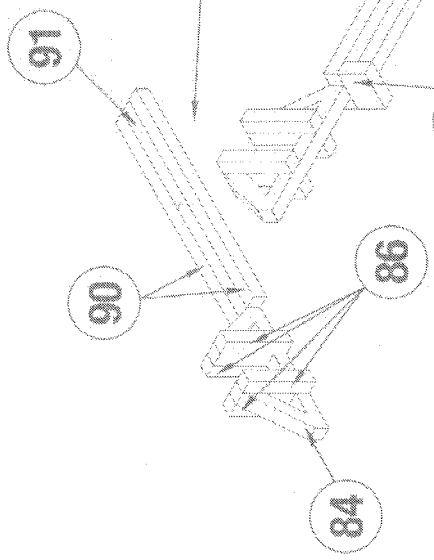
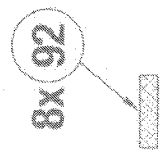
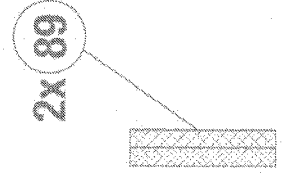
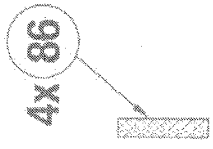
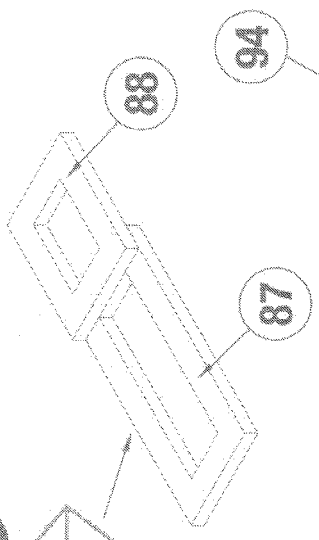
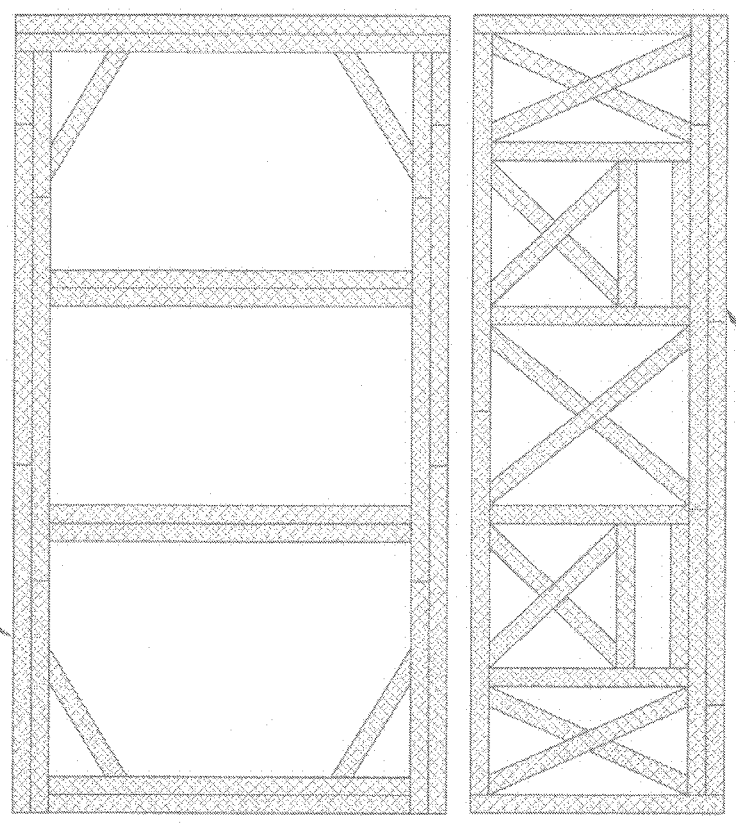
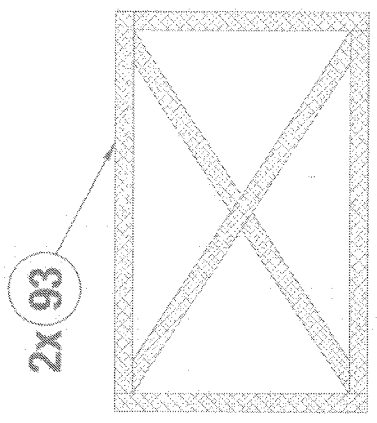
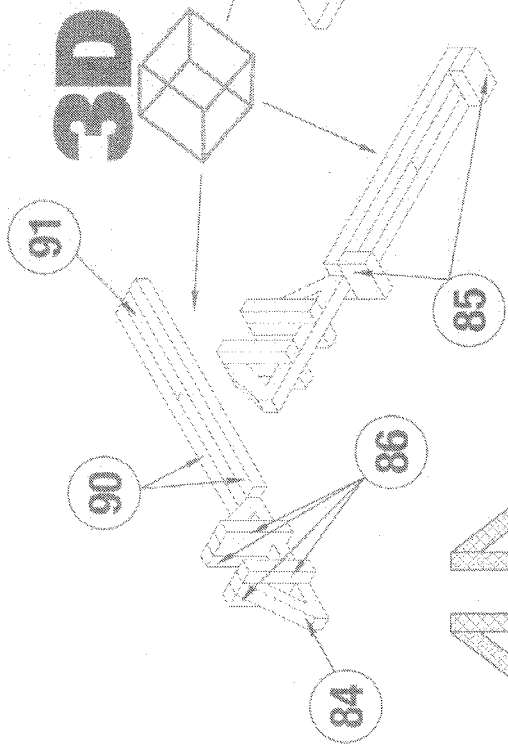

© 2004 Boleux Inc.

www.matchitecture.com

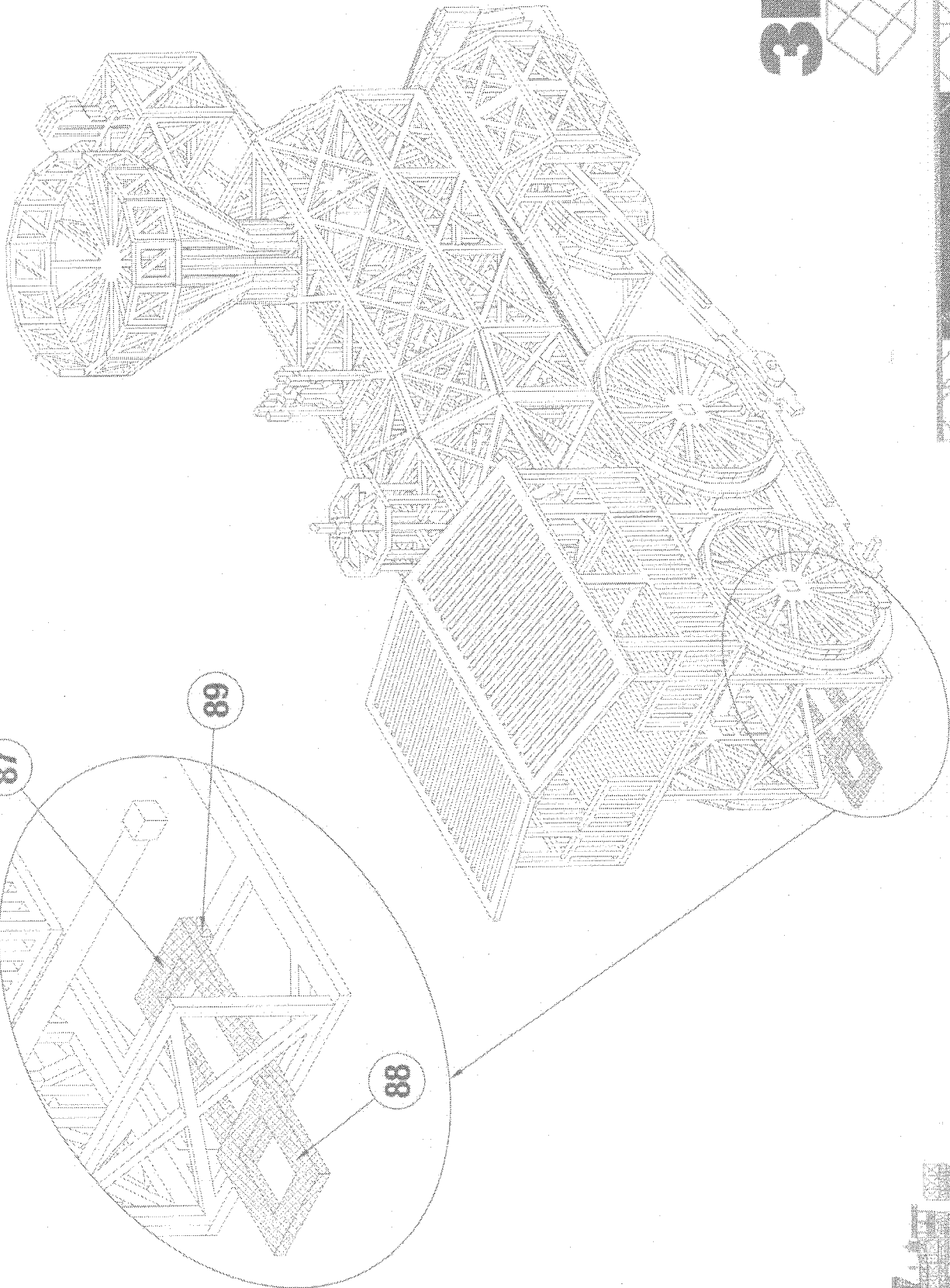

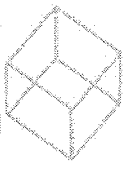
**3D** 



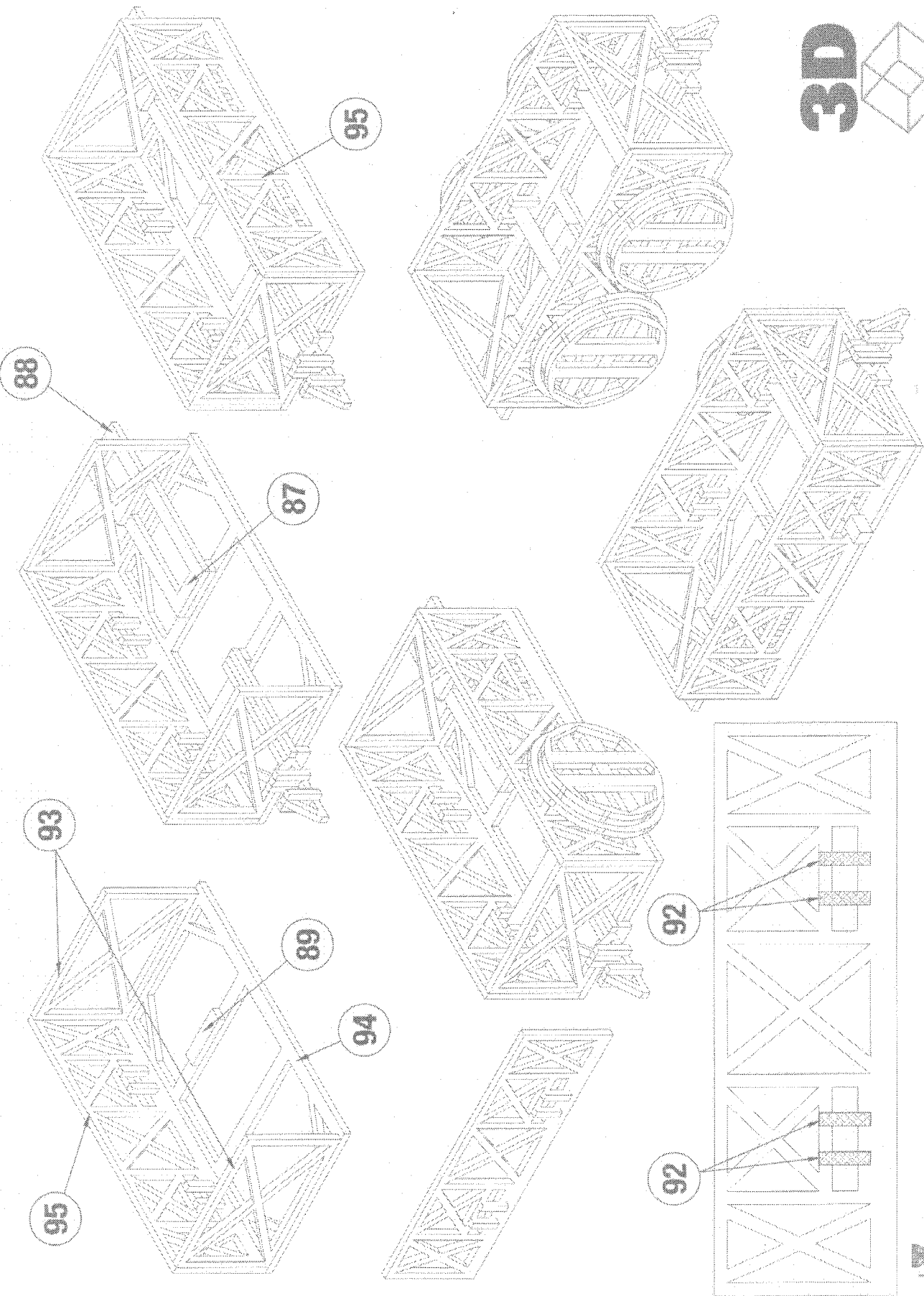

**3D**

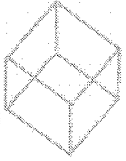

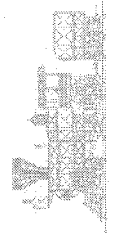
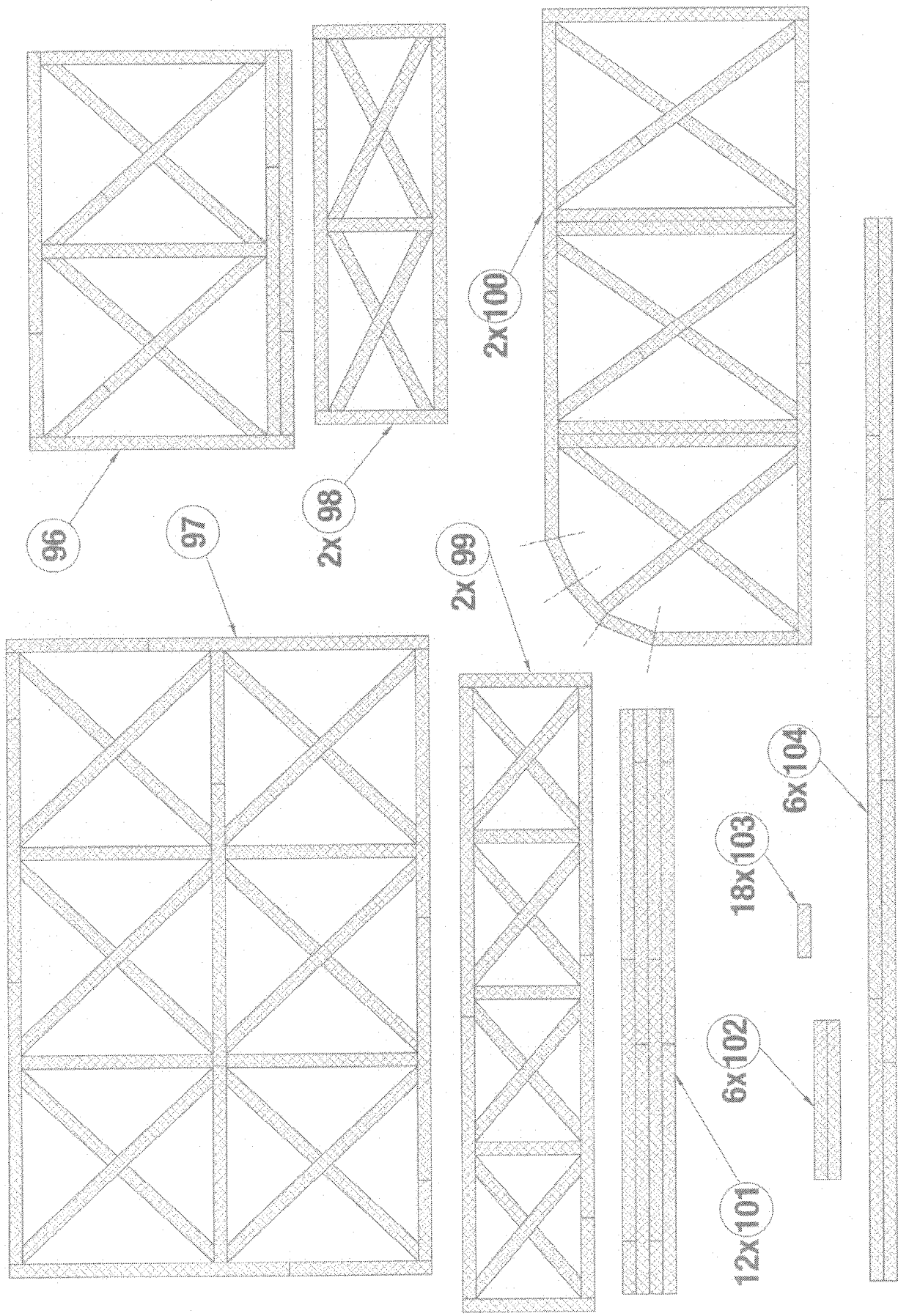

© 2004 Beata Inc.

www.matchitecture.com

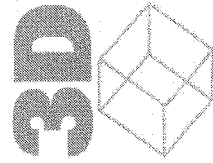
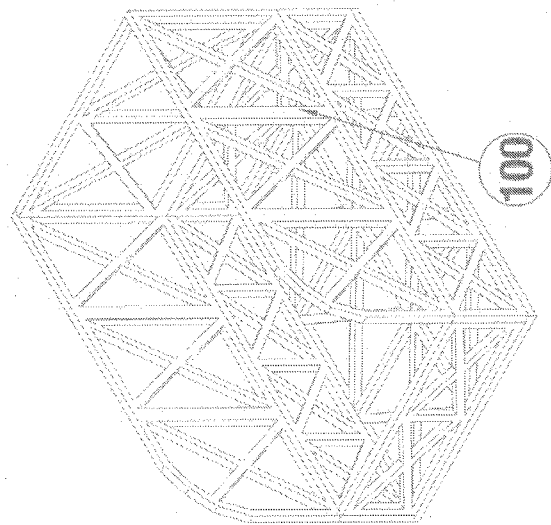
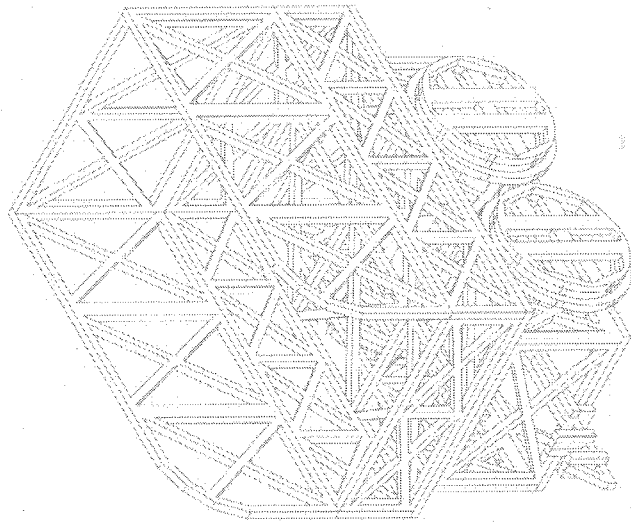
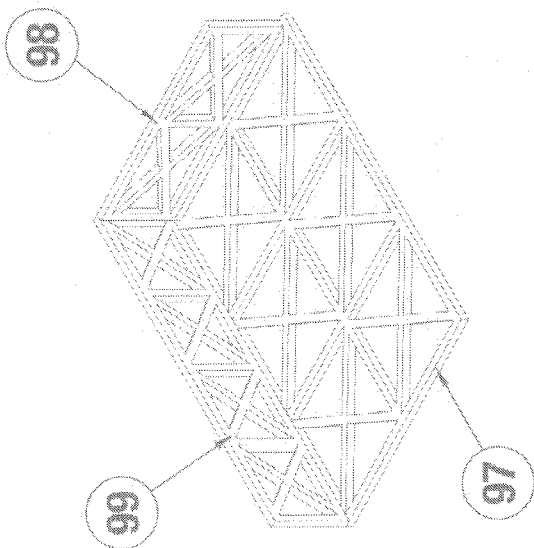
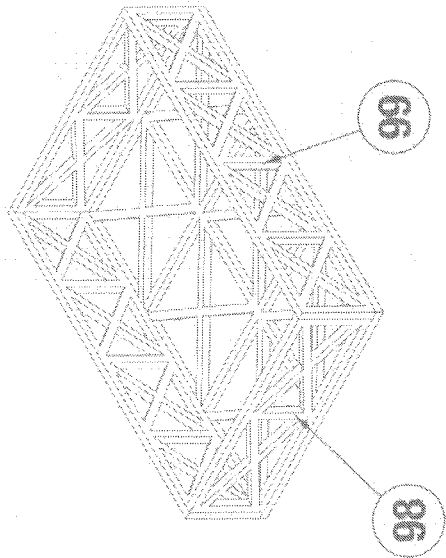
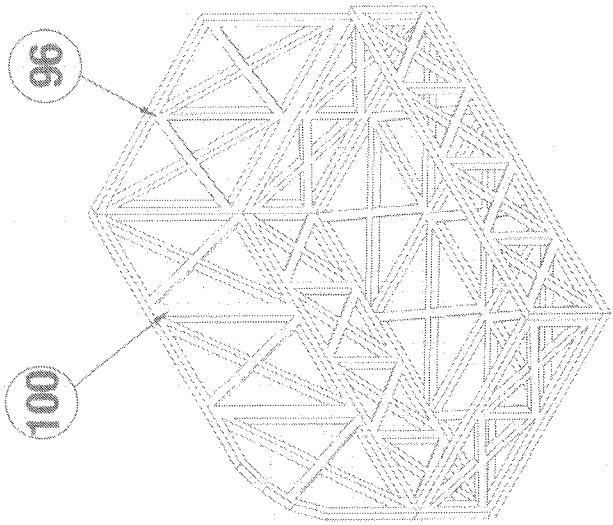

**3D** 

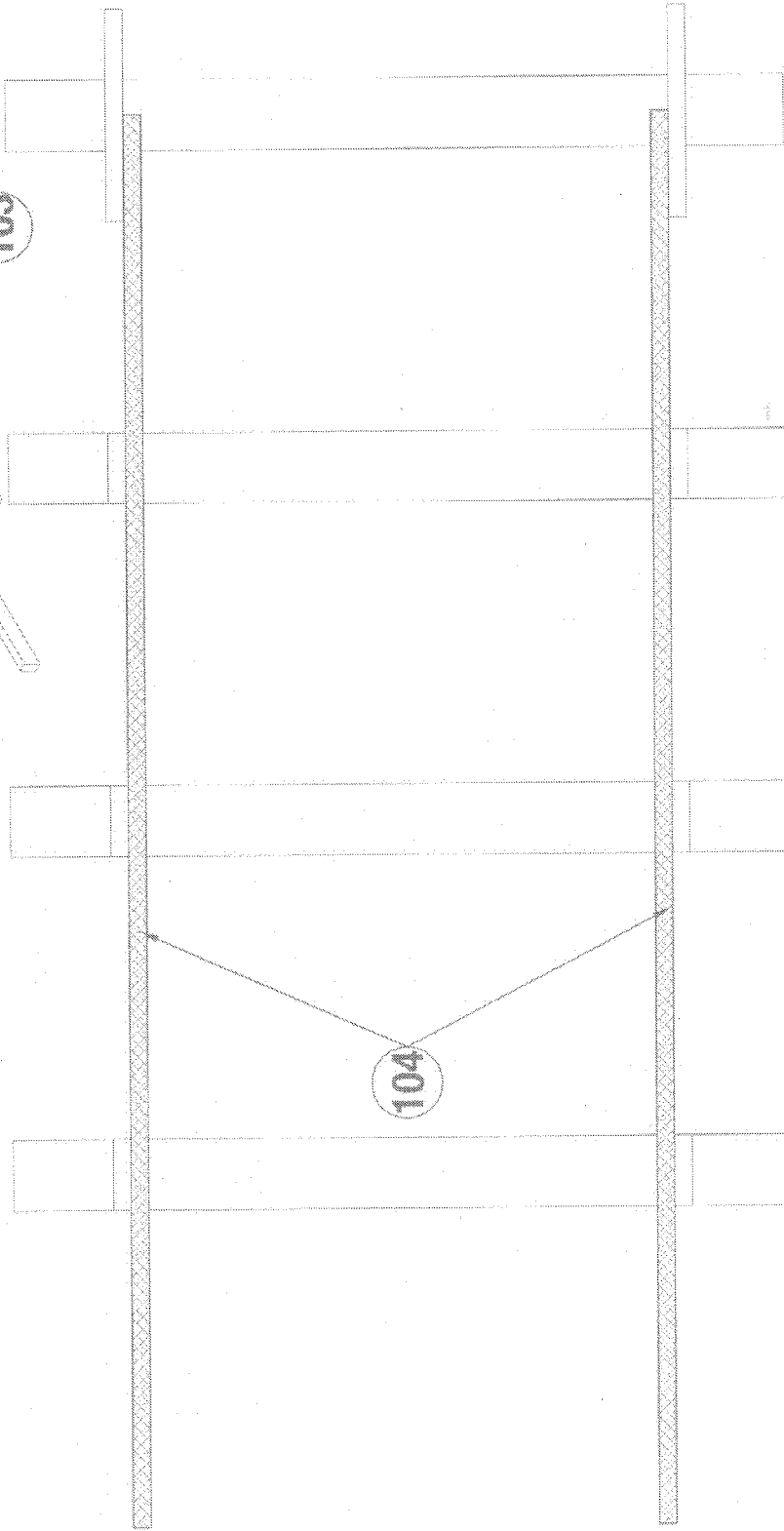
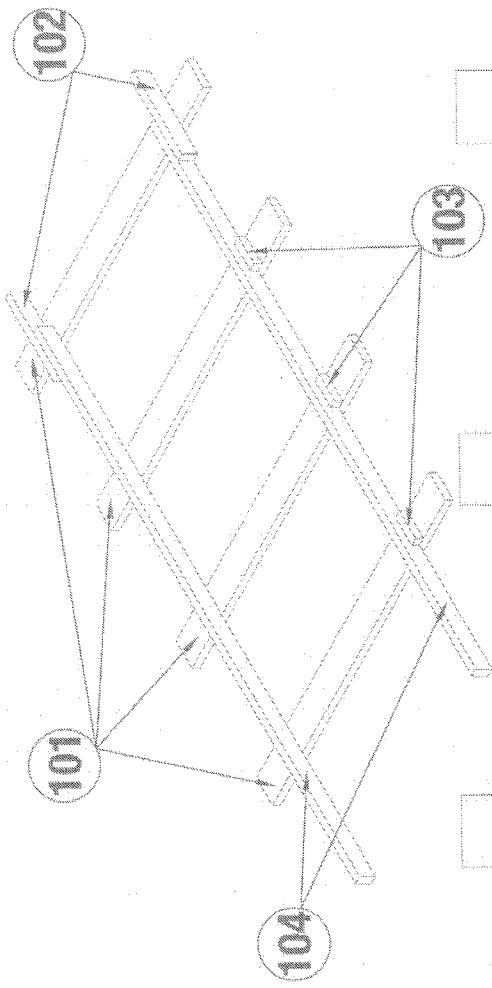

© 2004 B&B Inc.

[www.matchitecture.com](http://www.matchitecture.com)

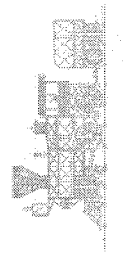
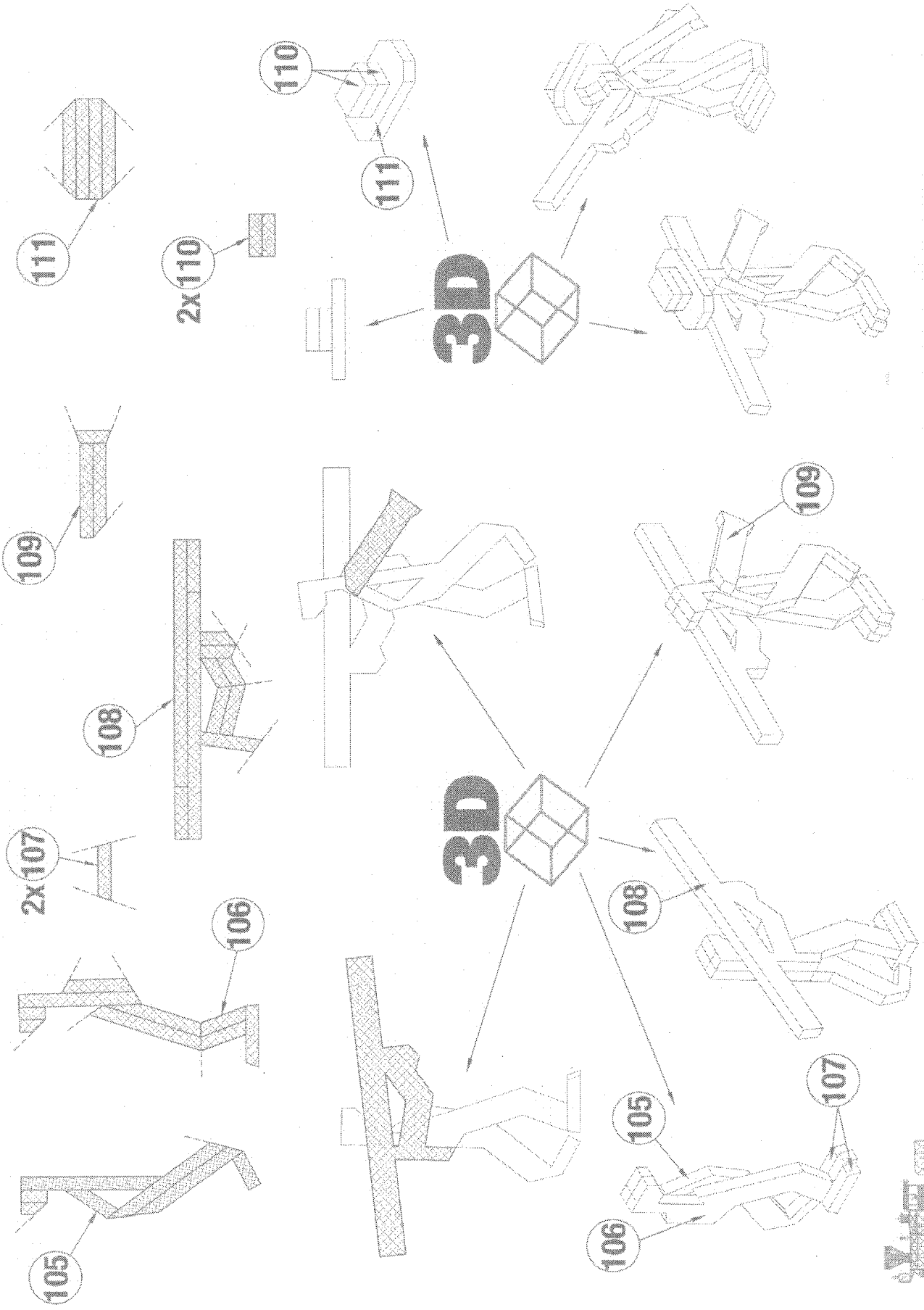

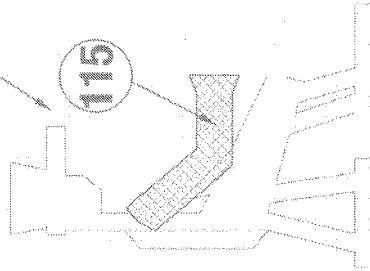
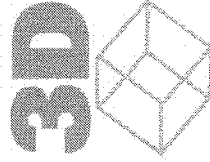
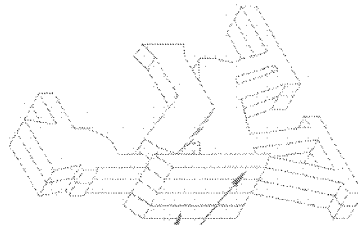
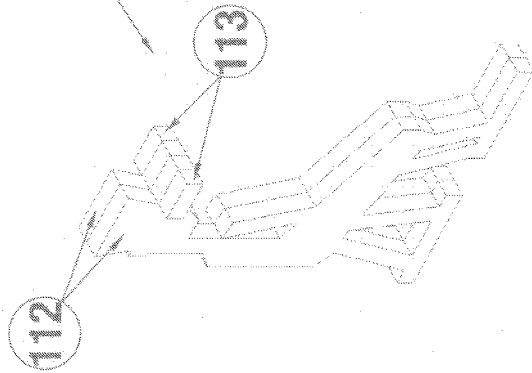
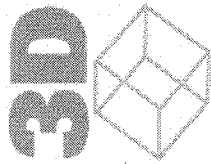
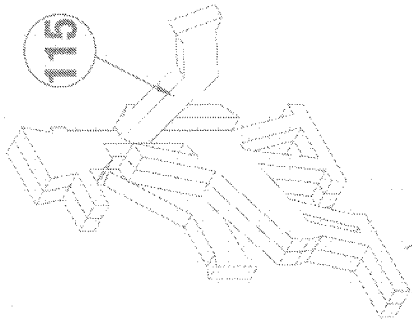
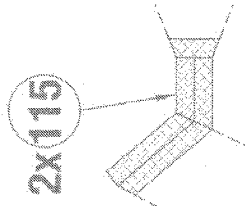
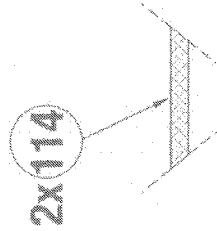
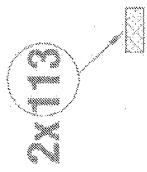
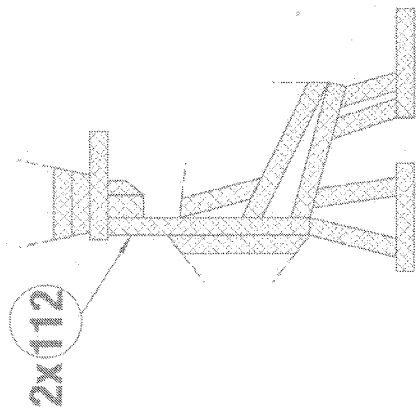

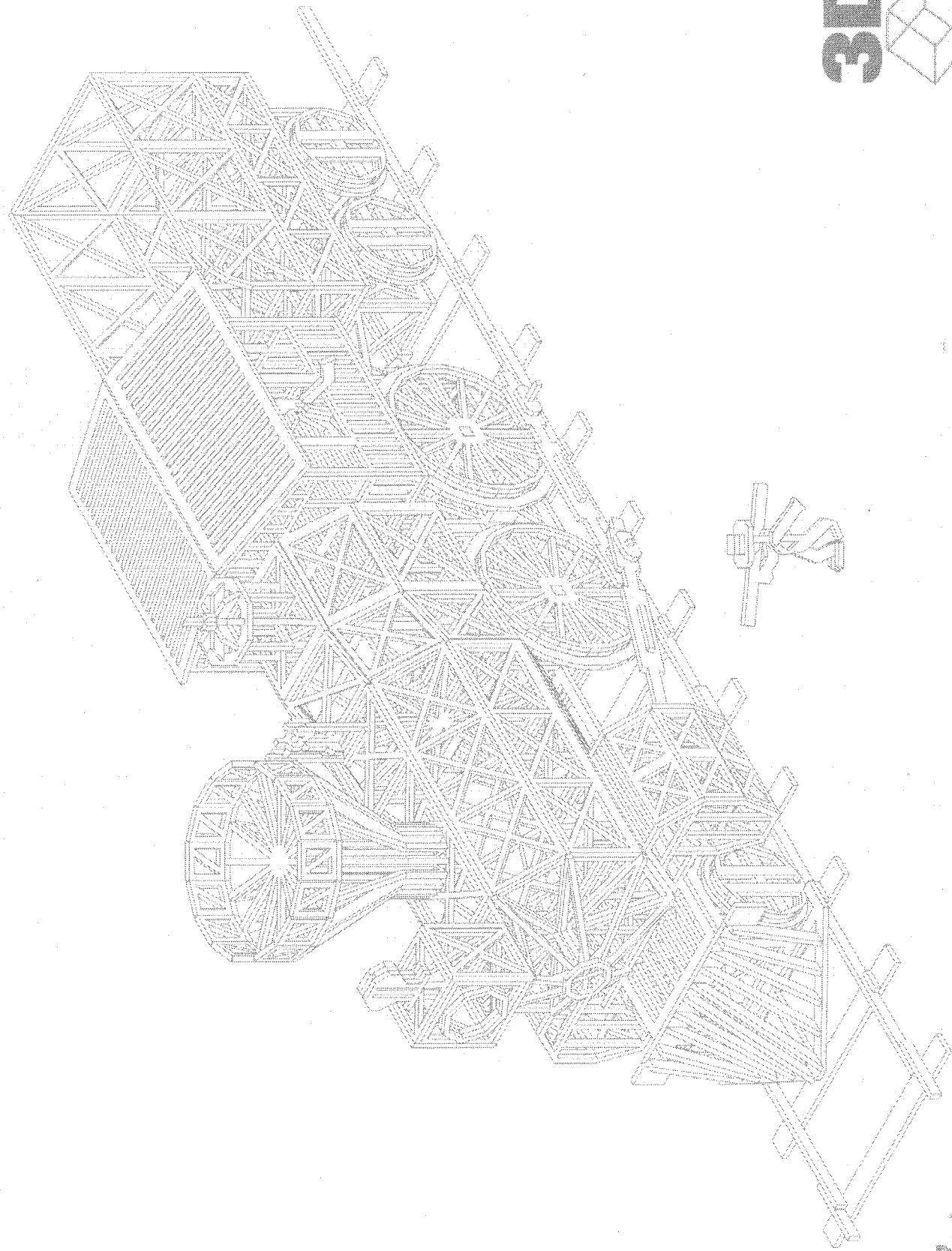

**3D**

